

# HORRIFIED



2024

REBEKAH BRYAN

HORRIFIED

# HORRORIFIED

DALLAS HORROR MOVIE MUSEUM  
REBEKAH BRYAN 2024

“..The painful fear inherent in the sublime is quickly converted to pleasure, as we realize that we are not in actual danger.”

**Comaroff and Ker-Shing, *Horror In Architecture***

## DR. A. RAY PENTECOST

DrPH, FAIA, FACHA, LEED AP | Co-Chair | Professor of Practice

## DR. STEPHEN CAFFEY

Ph.D. | Co-Chair | Associate Department Head

## DR. SUSANNEH BIEBER

Ph.D. | Committee Member | Associate Professor

## MARCEL ERMINY

Studio Professor | Professor of Practice

## ACKNOWLEDGEMENTS

Reflecting on the past year, this project has been an incredible journey for me. I've encountered struggles and had moments of success, all of which have pushed me to delve deeper than surface-level understanding. I would like to start by thanking Dr. Pentecost for taking a chance on this idea during his architectural programming class in the Spring of 2023. His unwavering enthusiasm gave me confidence to pursue this project further as my Final Study project. I'm also immensely grateful to my other two committee members, Dr. Caffey and Dr. Bieber, along with my studio professor Marcel, for their consistent encouragement and support throughout this project. Their belief in my ideas and goals, despite its unconventional nature, has been significant in my success.

Another round of thanks goes to my family and my fiance Miles, whose unwavering support has sustained me not only during this project but throughout my six years of education. I wouldn't be where I am today without them.

My largest and final thanks goes to my oldest sister, Bethany. Without her, this project wouldn't exist. She has shared her passion for horror movies and psychology with me since we were young, even when I resisted. It was my visit to her in Seattle where she took me to the Museum of Pop Culture, specifically to show me its horror movie exhibit. It was her two degrees in psychology and sociology that had me interested in how emotions could be evoked and manipulated. It was her persistence in showing me horror movies beginning at the age of six, despite my very clear and constant statement that I hated horror movies.

I am immensely grateful for the support and encouragement I've received throughout this process and look forward to sharing this project.

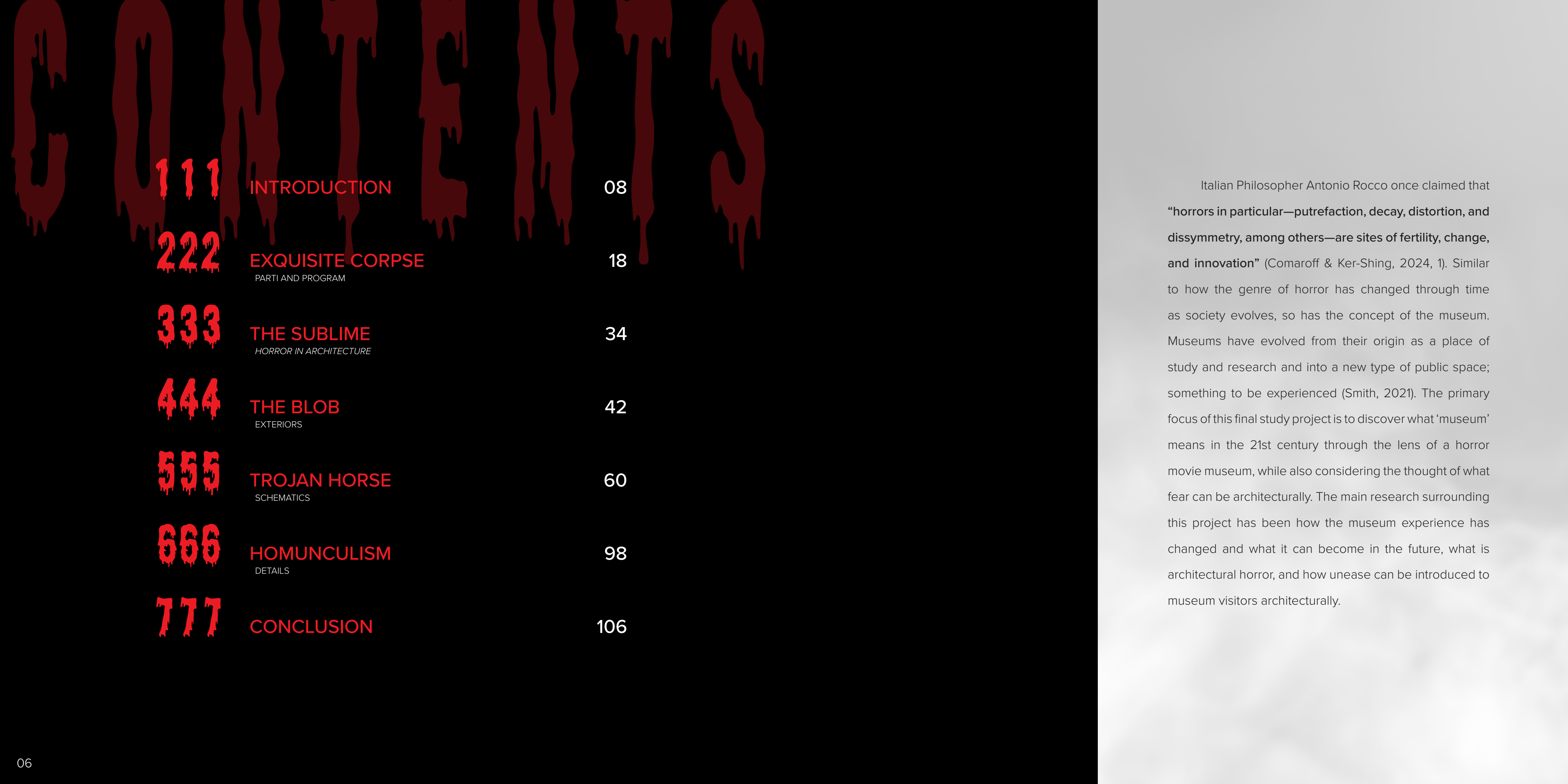

111

INTRODUCTION

08

222

EXQUISITE CORPSE

PARTI AND PROGRAM

18

333

THE SUBLIME

HORROR IN ARCHITECTURE

34

444

THE BLOB

EXTERIORS

42

555

TROJAN HORSE

SCHEMATICS

60

666

HOMUNCULISM

DETAILS

98

777

CONCLUSION

106

Italian Philosopher Antonio Rocco once claimed that “horrors in particular—putrefaction, decay, distortion, and dissymmetry, among others—are sites of fertility, change, and innovation” (Comaroff & Ker-Shing, 2024, 1). Similar to how the genre of horror has changed through time as society evolves, so has the concept of the museum. Museums have evolved from their origin as a place of study and research and into a new type of public space; something to be experienced (Smith, 2021). The primary focus of this final study project is to discover what ‘museum’ means in the 21st century through the lens of a horror movie museum, while also considering the thought of what fear can be architecturally. The main research surrounding this project has been how the museum experience has changed and what it can become in the future, what is architectural horror, and how unease can be introduced to museum visitors architecturally.

# III INTRODUCTION

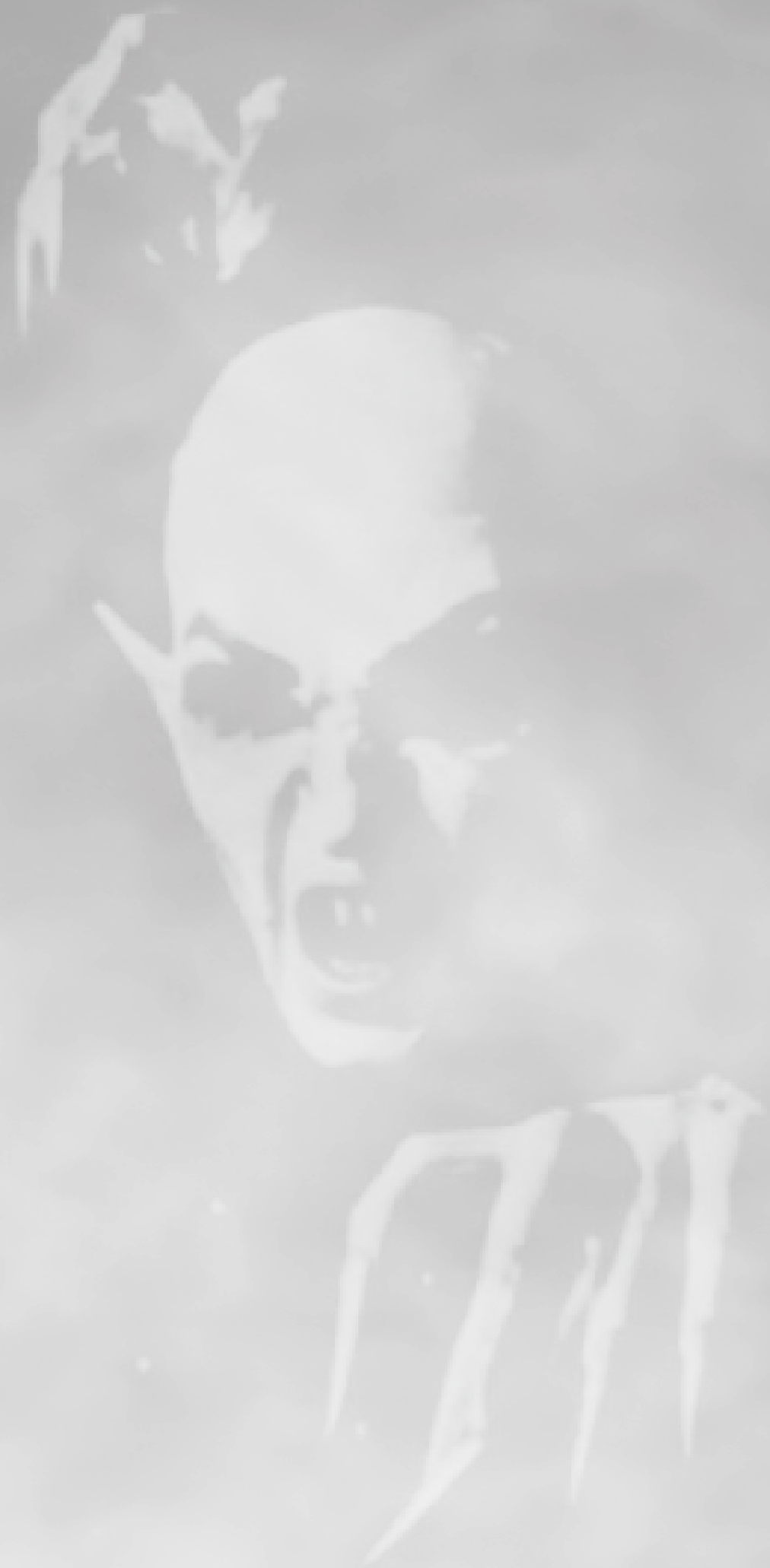

WHAT DOES 'MUSEUM' MEAN IN THE 21ST CENTURY?



# RE O RE RE O RE O RE O

Horror movies have been prevalent for centuries, dating back to the 1890's. The first horror movie has been debated by many as the genre was difficult to define, especially due to an influx of supernatural-themed films during the early 1900s (NYFA, 2022). It is believed that the first horror movie was *Le Manoir du Diable*, a short film by director George Melies created in 1896 that inspired the adaptation of the previously mentioned supernatural literary works in the 1920's (NYFA, 2022). Horror was being created during the boom of silent films, with works such as *The Cabinet of Dr. Caligari* in 1920 and the classic *Nosferatu* in 1922 (NYFA, 2022). Works at this time were essentially created as an **“attempt to unsettle their audience,”** eventually beginning **“to worry the general public”** and create controversy surrounding the genre that is still prevalent to this day, although less so in the past decade (NYFA, 2022). As time went by, the genre continued and picked up steam, although still an outcast to the public. Sub-genres such as slasher, supernatural horror, and disaster marked the era of the 40s and 50s, while possession, gore, and low-budget films became popular in the 60s, 70s, and 80s (NYFA, 2022). The most solid foundation for the current

evolution of horror films occurred in the late 70s and 80s with films such as *Carrie* (1976) and *The Shining* (1980) (NYFA, 2022). True success came with cult classic films of the 80s and 90s, even introducing the idea of comedy or spoof horror in the way of *Scream* (1996) which pointed out the repetitive tropes of horror while fulfilling the goal of the first horror films; to entertain (NYFA, 2022).

What is clear in even the most basic history of horror films is the evolution that the genre has gone through. **“Horror is one by-product of modernity and thus mimics its advanced forms,”** (Comaroff & Ker-Shing, 2024, 2) evolving with changing cultural norms and society. What made each film scary or unsettling in their own right was the internal feelings by the viewer. In a 2019 interview on why we enjoy fear, Texas A&M professor Stephen Maren stated that **“with fear as entertainment, whether in movies or haunted houses, people can enter into those situations knowing that ultimately there is no real danger,”** (Poth, 2019) making horror films enticing to those who want a thrill, or even pleasure.

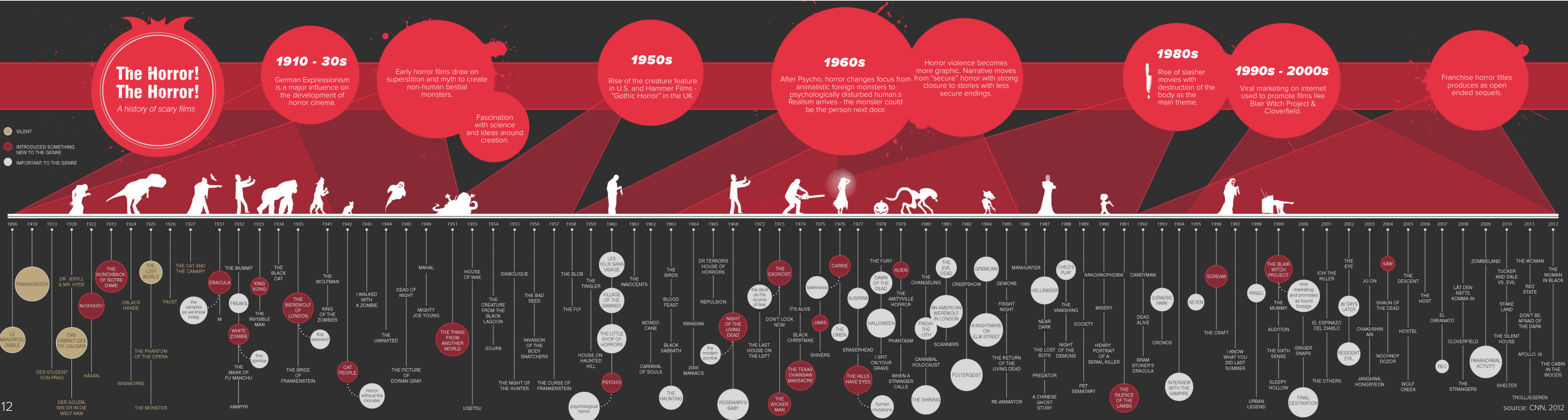



MUSEUM OF POP CULTURE / SEATTLE, WASHINGTON / FRANK GEHRY



I was able to experience *Scared to Death*, the Horror Exhibit at the Museum of Pop Culture in Seattle, Washington in 2018 on a trip to visit my sister who lived there at the time. The focus of this exhibit, besides displaying a collection of movie props, was to question why we like horror movies if they scare us. As seen in the photo on the right, the entry wall states that “we enjoy horror film[s] because it is equally conformist & subversive” (MoPOP, n.d.), which is just one answer to the question I continued to ask throughout the production of this project. According to the exhibit description, “themed gallery sections evoke the unsettling sensations associated with cinematic terror” (MoPOP, n.d.), which is one of the goals of the Dallas Horror Movie Museum, and was a design factor used throughout the project. When considering my options with project selection, I knew this subject was a valid choice of project as it has been proven to be a successful and entertaining exhibit for this museum.



An indisputable fact of horror movies is that they must have a setting, whether involving a building or not. Horror settings tend to be houses or hotels; somewhere the characters feel safe and secure. **“But what happens when the physical space around us creates feelings of disorientation and dread rather than feelings of comfort, predictability, and security?”** (McAndrew, 2020) This sense of security heightens the fear level of the viewer when they have to think about the fact that their safe spot may not actually be safe at all. There are even iconic horror houses, such as the house behind the Bates Motel from Psycho (1960), which itself was inspired from the Victorian era house in Edward Hopper’s House by the Railroad (Woods, 2022). These Victorian homes were large, like mansions, and were often abandoned by the wealthy after times of war and income inequality, with the characteristics such as severe angles, woodwork, and decay becoming prevalent in the common trope of abandoned buildings within horror (Woods, 2022) (Vox, 2018). Within American cinema there is “a subgenre of horror focused on buildings, buildings that are themselves the sources of evil” (Eggener, 2013). The building can act as an antagonist or be a medium through which to show a bigger picture. In Parasite (2019), the architecture and urban landscape used throughout the entire film is used as a way to express the vertical hierarchy of the Korean caste system, with the wealthy living safely on a hill while the poor get flooded at the bottom of the terrain (Flight & Lazarraga, 2020). It is clear that there is architecture within the genre of horror, but what can be found of horror in architecture?

# VISUAL THESAURUS

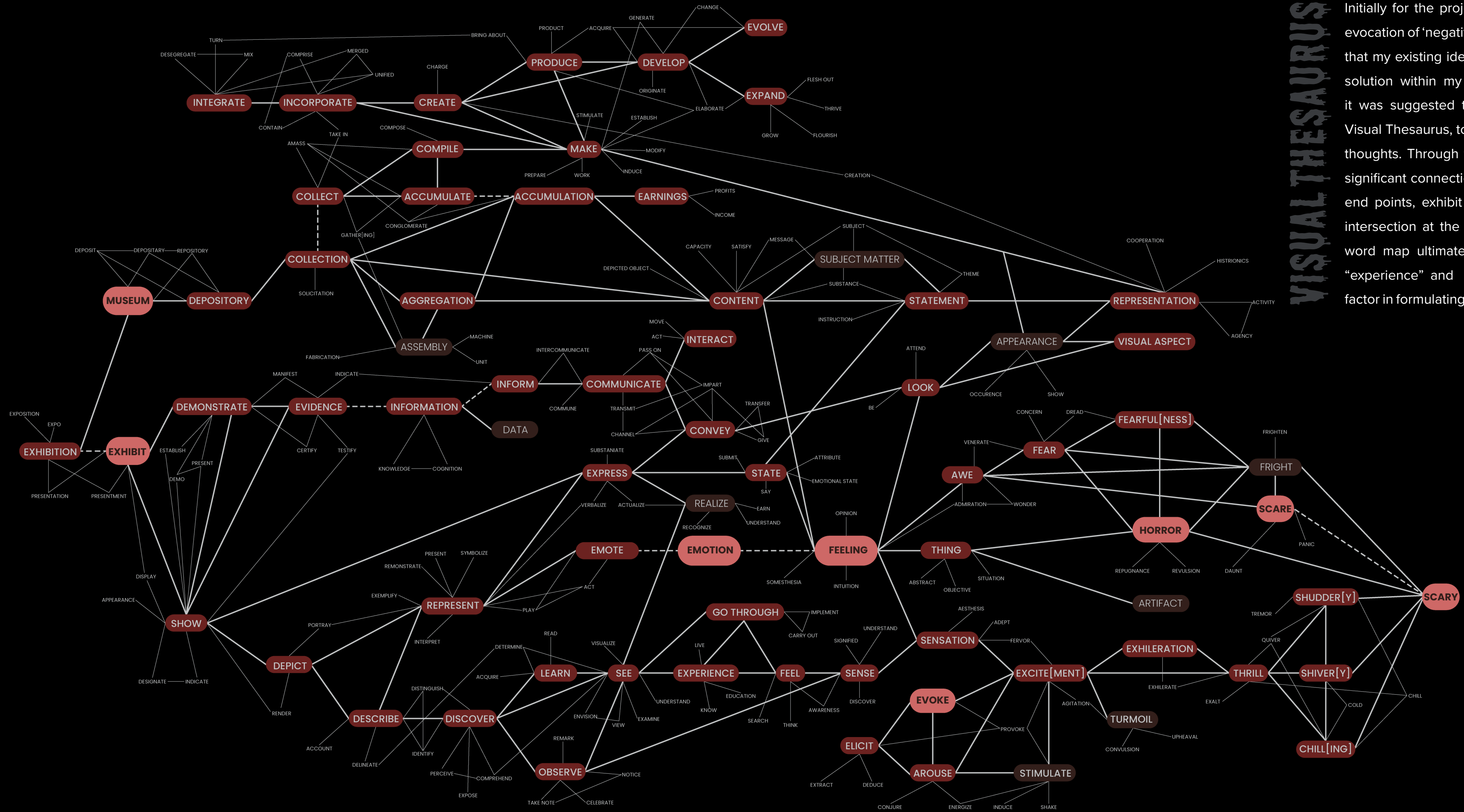

Initially for the project, my focus was on the evocation of ‘negative’ emotions, but I realized that my existing ideas lacked an architectural solution within my capabilities at that time. It was suggested to use an online service, Visual Thesaurus, to create a word map of my thoughts. Through this process, I discovered significant connections between my start and end points, exhibit and scary, with a critical intersection at the concept of emotion. This word map ultimately guided me to identify “experience” and “immersion” as a central factor in formulating my architectural question.

222

EXQUISITE CORPSE



An aerial photograph of Dallas, Texas, showing a dense urban grid, major highways, and green spaces. A red circle is overlaid on the image, highlighting a specific location in the downtown area, near the intersection of several major roads.

# DALLAS, TEXAS

Beginning this project, I wanted to remain somewhere that I was previously familiar with. Having spent my entire life in the DFW area, mainly on the Fort Worth side, I initially focused my search for sizable, vacant plots in Fort Worth. As I explored the museum district in Fort Worth, I was unable to find a lot that I felt would fit the project. I shifted my attention over to Dallas, recognizing its potential alignment with the project's objectives due to its distinct cultural identity compared to Fort Worth, despite being part of the same metroplex.

In Dallas, particularly in Downtown, I discovered multiple viable options. Ultimately, I settled on an existing parking lot situated across the highway from the Perot Museum, centrally located in Downtown Dallas. Notably, this lot falls within the West End Historic District, adjacent to numerous significant projects in the Dallas Arts District. This strategic positioning offers visitors a prime opportunity to not only explore this distinctive museum but also access other key attractions in the vicinity.



# 1100 MCKINNEY AVE.

SITE: 205,000 SF

CURRENT: PARKING LOT | Zoning: CA-1(A)

ADJACENT: The Perot | Dallas Aquarium



Bike Lane Map

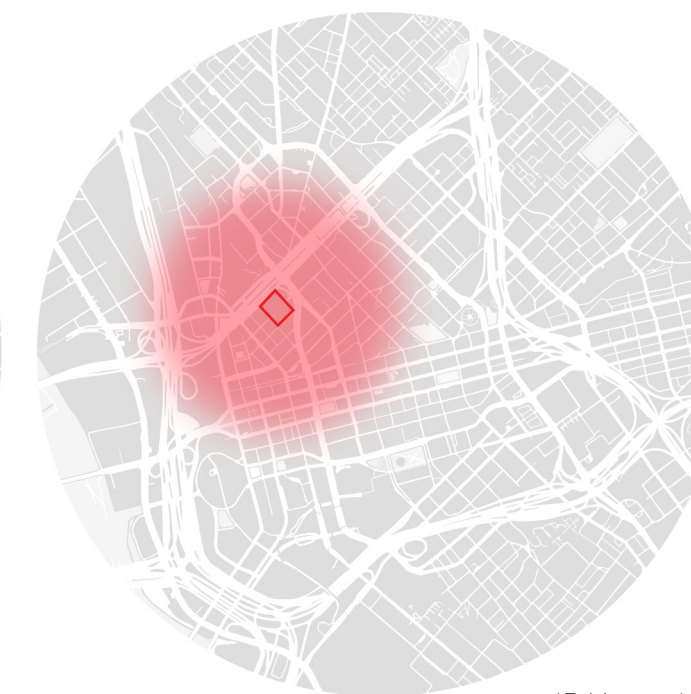

15 Minute Walk



Flood Plain

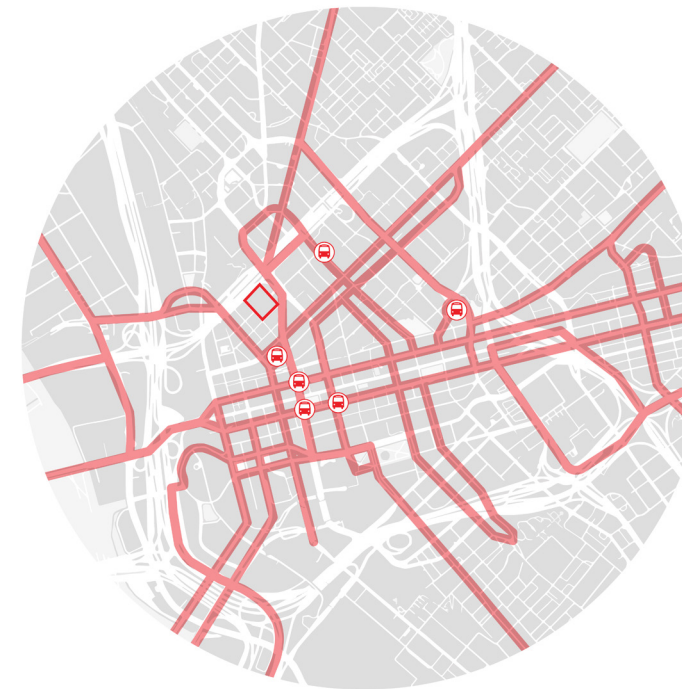

Bus Map



6pm Traffic

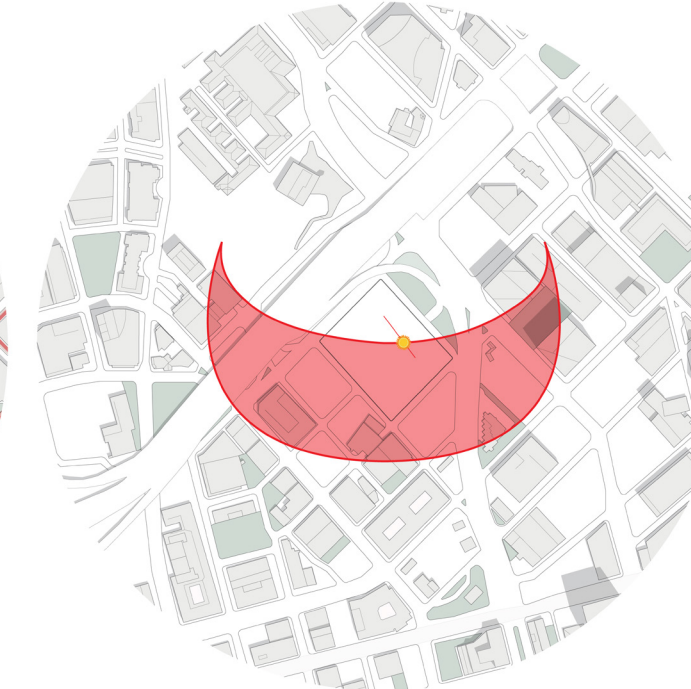

Summer Solstice

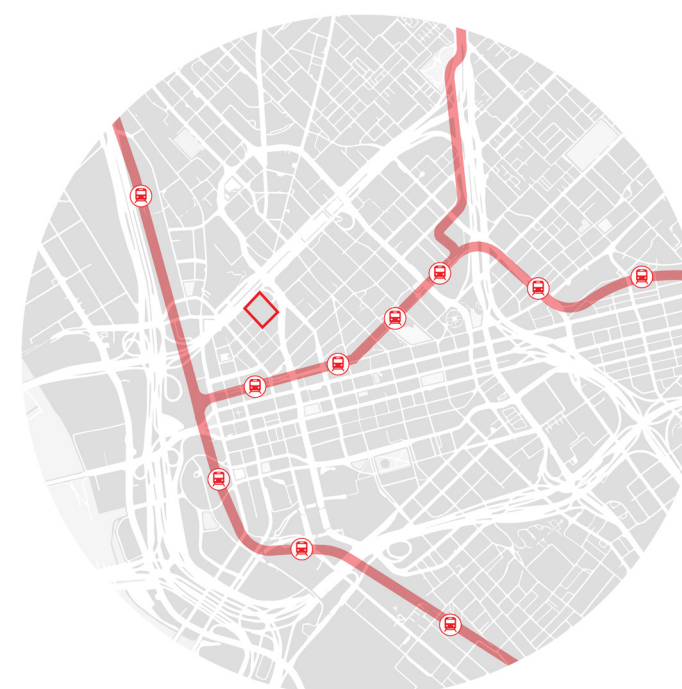

DART Map



Street Direction



Winter Solstice



The museum typology is, like horror movies, a product of societal evolution. The most basic definition of a museum is **“an institution devoted to the procurement, care, study, and display of objects of lasting interest or value”** or **“a place where objects are exhibited”** (Merriam-Webster, n.d.). Traditionally, museums were more for study and research and not for the public, but they slowly transitioned into something more public while many maintained the study and research elements (Smith, 2021). As the idea of the museum evolved into being more for the public display of art, the building containing the art was not a primary concern, with some collections being on display in a person’s home while others were in existing public spaces (Smith, 2021). Beginning in the late 1930’s, there was a group of popular architects that wanted the more formal museums to be designed in the international modernism style, while **“at the same time, the dominance of the Museum of Modern Art and its sense of its own intellectual authority provided a model which later museums, and particularly later curators, came to dislike and, from the early 1970s, reacted against”** (Smith, 2021, 30). As a reaction to this disdain for the previous museum design, present in the seventies and eighties was the **“high point of museum architecture where Postmodernism brought with it a return to historicism and hence a renewed central role for the museum as a building task”** (Achleitner, 1999, 12). In *Museums for a New Millenium*, Swiss art historian Stanislaus von Moos brings

up the idea of four types of museum typologies, with the fourth being the **“museum as a sculptural object”** (Achleitner, 1999, 20), which became a concept of this horror movie museum project and its exterior. **“Museums are buildings that must respond to highly representative and aesthetic demands, while also fulfilling specific requirements with regard to urban design and function. The latter two are all the more complex because they are dictated by the art on exhibit within the building”** (Achleitner, 1999, 7), and the collections on display within this building are non-traditional, but worth experiencing.

Upon working through the word map using Visual Thesaurus, the concept of the museum experience gained significance, as did pinpointing the areas frequented by visitors or tourists throughout the city. In addition to understanding the competitive landscape for attracting these visitors, establishing connections with similar building typologies emerged as a key motive for this analysis. Illustrated on page 24, the drawing emphasized the pivotal axis linking the project site with the Dallas Museum of Modern Art and other prominent structures along Flora Street in Downtown. Recognizing the significance of physical connectivity during the site analysis, it became imperative to identify nearby establishments catering to similar customer demographics and interests.

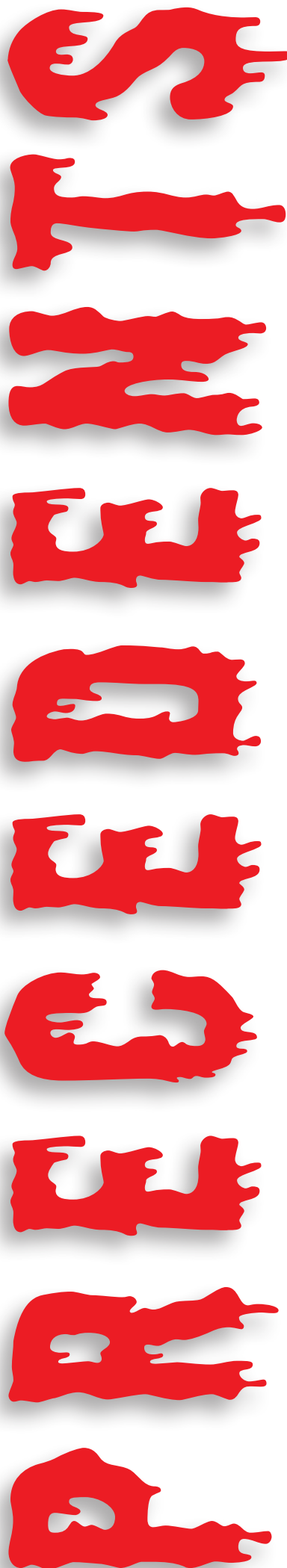

In preparation for this project, I was able to take a trip to Washington D.C. in the summer of 2023 and visit museums. I have been to plenty of traditional art museums, so I took this opportunity to attend museums that could be seen as ‘non-traditional’ and were focused on an interactive experience and visitor immersion, two concepts that the project was to focus on. On this trip, I was able to visit the International Spy Museum, an interactive experience where the visitor is given a spy identity and must solve a crime through checkpoints throughout the museum, Planet Word, a word based museum focusing on English and Foreign language, and Artechouse, an interactive and motion based art experience that at the time of my visit, was displaying PIXELBOOM: Timeless Butterflies. I not only got to experience these museums as a visitor, but also through the eye of an architectural designer scoping out a potential project type.

There are additional architectural precedents that were used throughout the design of this project, with the three chosen projects primarily being used during the programming process of the project. The museum typology is something completely foreign to me, so these projects assisted in determining the sizing of spaces. Additionally, the Academy Museum of Motion Pictures is a similar program type with the display of movie props. This museum’s new addition also contains a new movie theater, which is a major space that is present in the Horror Movie Museum.

**INTERNATIONAL SPY MUSEUM**

WASHINGTON, D.C. / ROBERT STIRK HARBOUR + PARTNERS



**ARCTEHOUSE**

WASHINGTON, D.C. / SANDRO KERESOLIDZE (FOUNDER)

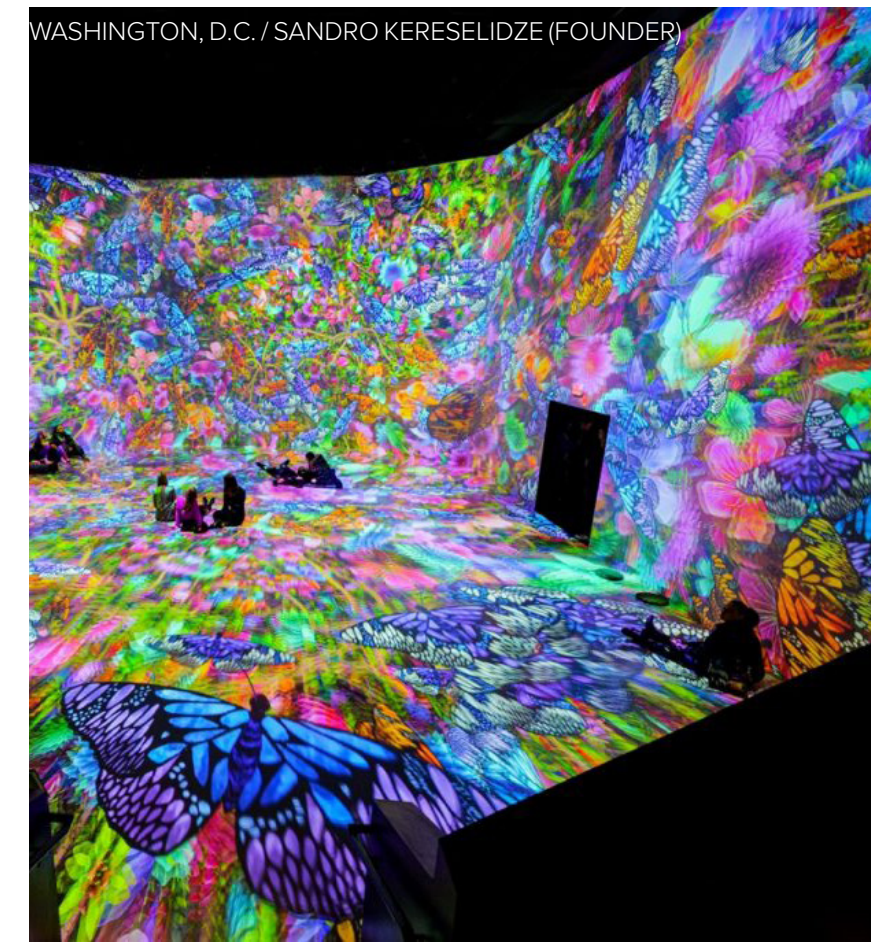

**PLANET WORD**

WASHINGTON, D.C. / BEYER BLINDER BELLE



**FORT WORTH MUSEUM OF SCIENCE + HISTORY**

FORT WORTH, TX / RICARDO LEGORRETA LEGORRETA



**ACADEMY MUSEUM OF MOTION PICTURES**

LOS ANGELES, CA / RENZO PIANO (ADDITION)

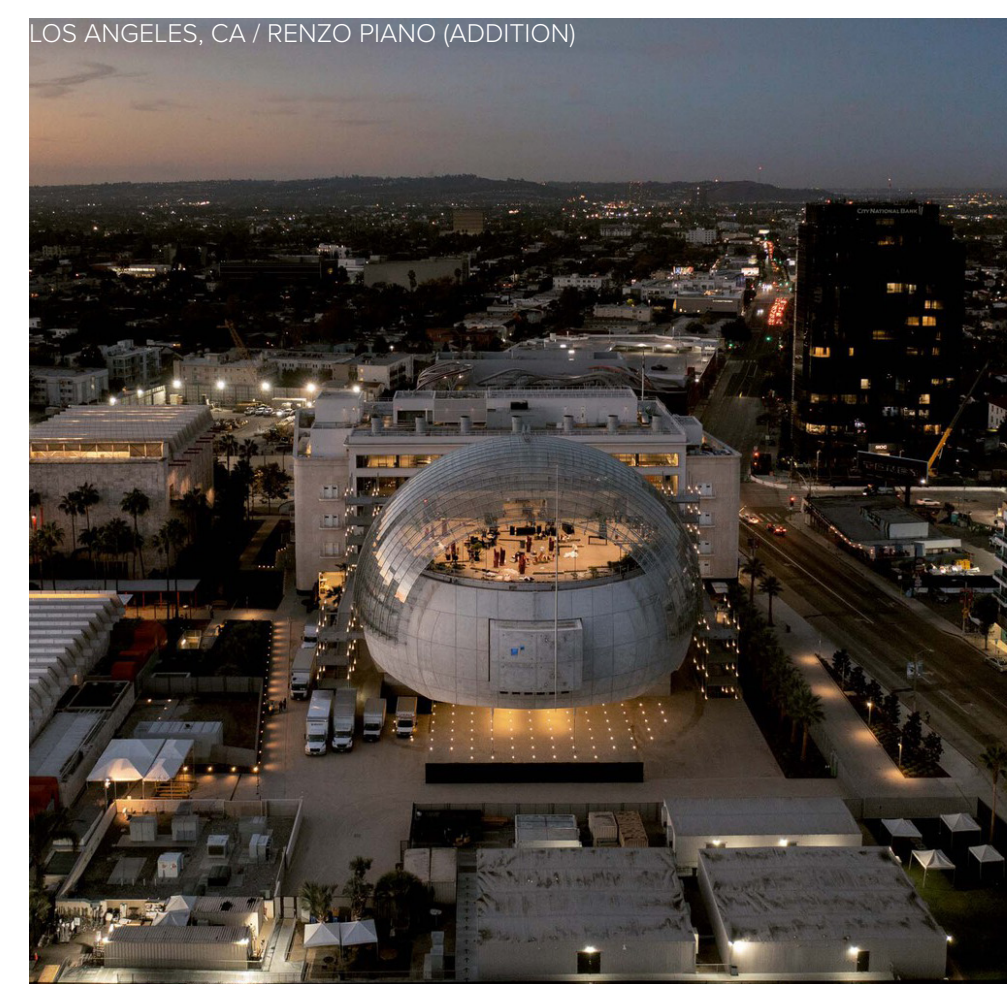

**ISTANBUL MODERN MUSEUM**

ISTANBUL, TURKEY / RENZO PIANO



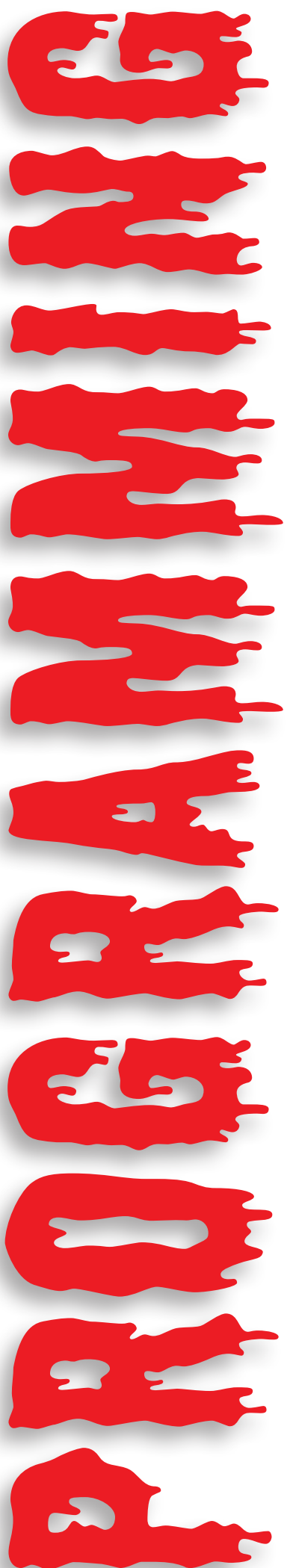

I was fortunate to take architectural programming with my Co-Chair Dr. Pentecost in the spring of 2023. This class allowed me to get a head start on the programming aspect of my project. Many early developments in the program of this project were determined through this class and multiple class discussions.

FUNCTION RELATIONSHIPS				
GOAL	FACTS	CONCEPT	NEEDS	PROBLEM STATEMENT
To have a main connection to the different activities	<ul style="list-style-type: none"> <li>• Exhibits is half of the overall space</li> <li>• Building must have an entrance</li> <li>• Interactive displays and activities will create hotspots</li> <li>• Movie screenings will be in a different area than the regular exhibit and will require a separate ticket</li> <li>• Merchandise and food needs to be accessible to everyone</li> <li>• People will have to purchase tickets</li> </ul>	Mixed Flow	<ul style="list-style-type: none"> <li>• Main hub at entrance with connections to kids area, retail/food, seasonal exhibit, permanent exhibits, theater, and administrative/employee area</li> <li>• Circulation with activity placement in mind</li> <li>• Separate entrance for movie screening area with separate circulation and entry ability</li> <li>• Merchandise in food at locations accessible to every flow of people</li> <li>• Easy to find and accessible ticket area / reception + information desk</li> </ul>	There needs to be thought out and planned spatial relationships that benefit the business, the visitors, and the overall immersive experience through the use of themed activities, a central commerce area, and the overall use of architecture to invoke emotion.
In order for this project to be successful...				
There needs to be thought out and planned spatial relationships that benefit the business, the visitors, and the overall immersive experience through the use of themed activities, a central commerce area, and the overall use of architecture to invoke emotion.				

FUNCTION ACTIVITIES				
GOAL	FACTS	CONCEPT	NEEDS	PROBLEM STATEMENT
To have a seasonal exhibit that will cause fear to patrons	<ul style="list-style-type: none"> <li>• There is a movie themed for many holidays and seasons that would benefit from a special exhibit</li> <li>• Exhibit visitors will be extra</li> <li>• Provide an opportunity for those who seek extra thrills</li> <li>• Will require protection but can induce new interest in the museum</li> <li>• Special merchandise can be produced for seasonal exhibits</li> <li>• Fear can be produced in many ways</li> <li>• Visitors cannot be able to see the end of the exhibit upon entering</li> <li>• Wandering paths make people uneasy</li> </ul>	Sequential Flow	<ul style="list-style-type: none"> <li>• Useless walkways and wall measurements with winding paths</li> <li>• Encroaching of corner</li> <li>• Limited space</li> <li>• Blurred</li> <li>• Dark corners</li> <li>• Can scatter or whatever emotion is required per the exhibit, as the exhibit goes on</li> <li>• Separate entrance and exit</li> <li>• Special cut that routes patrons to the main circulation area</li> <li>• Seasonal exhibit area in retail shop</li> <li>• Themed food service products</li> <li>• Themed employee uniforms</li> <li>• Speakers for sound effects</li> <li>• In over all central system</li> </ul>	
This exhibit and activities are offered for all age ranges	<ul style="list-style-type: none"> <li>• Monitor range from G to NK</li> <li>• Children will attend</li> <li>• People enjoy different types of horror films</li> <li>• Decisions will not have equal amount of content</li> <li>• Activities on a different scene of revenue</li> </ul>	Activity Grouping	<ul style="list-style-type: none"> <li>• Children's Area</li> <li>• Seasonal Exhibit Area</li> <li>• Permanent Exhibit Area with sub-sections for: <ul style="list-style-type: none"> <li>• General Home</li> <li>• Slader</li> <li>• Supplemental</li> <li>• Occult / Folk</li> <li>• Creative Business</li> <li>• Foreign</li> <li>• Religion</li> <li>• Spiritual</li> <li>• Elevated</li> </ul> </li> <li>• Commercial area including: <ul style="list-style-type: none"> <li>• Cafe (see economy)</li> <li>• Retail (see economy)</li> <li>• Photo opportunities</li> <li>• Small theater</li> </ul> </li> <li>• Administrative area</li> <li>• Activities outside of the exhibits</li> <li>• Interactive displays in permanent exhibit</li> <li>• Sun through digital and branch into sub genres</li> <li>• Small theater for special screenings</li> <li>• Security camera</li> </ul>	

FORM SITE				
GOAL	FACTS	CONCEPT	NEEDS	PROBLEM STATEMENT
To create an efficient environmental response	<ul style="list-style-type: none"> <li>• Temperatures can change seasonally</li> <li>• Annual average temperature range is 11 to 97 degrees</li> <li>• Summer high is 102 degrees, winter low is 49 degrees</li> <li>• Wind primarily comes from the south with most speeds coming from the south and northeast</li> <li>• Relative humidity is above outside of comfort zone</li> <li>• Dry bulb temperature is often outside of comfort zone</li> </ul>	Environmental Controls	<ul style="list-style-type: none"> <li>• Smaller spaces for exhibits for controlled conditions</li> <li>• Customer base to provide relief for dehumidification to reduce dehumidification energy costs</li> <li>• Low energy features such as high frequency lighting and shades</li> <li>• Exterior shading around entrances and windows</li> <li>• Natural light to the north with shading on the south</li> <li>• Airtight structure with high thermal mass</li> <li>• Different interior climate zones</li> </ul>	Systems need to be in place to reduce environmental impact as well as reduce cost through use of these systems.
To avoid reliance on the Texas power grid	<ul style="list-style-type: none"> <li>• Texas has had power grid failures lately</li> <li>• Solar is a cleaner form of energy</li> <li>• Average cost is \$10,000 for solar panels</li> <li>• Will take 8 years to break even</li> <li>• Optimal roof angle is 30 degrees</li> </ul>	Self Reliability	<ul style="list-style-type: none"> <li>• Power the whole building with its own energy</li> <li>• Solar panels on roof</li> <li>• Roof made 10 degrees angle for solar panel installation</li> <li>• Insulation</li> <li>• Roof cover for maintenance</li> <li>• Hidden to public</li> </ul>	
In order for this project to be successful...				
Systems need to be in place to reduce environmental impact as well as reduce cost through use of these systems.				

1.0 Catchment	
Entry Vestibule	96
Security Area / Monitoring Station	480
Lobby	9600
Admissions / Tickets	256
Museum Store	4800
Museum Store Storage	480
Cafe	1536
Cafe Storage / Kitchen	480
Coatroom	128
Restrooms	192
Resource Center	960
Flexible Special Event Area	1536
Education Room	768
Janitorial	64
Employee Breakroom	192
Employee Restrooms	96
Employee Locker Rooms	192

2.0 Exhibit / Program	
Orientation Room	576
Child's Area	2304
Temporary Exhibit	11520
Temporary Exhibit Shop	96
Permanent Exhibits	20736
Rotating Exhibits	14400
Staging Area	4800
Restrooms (singles)	96

3.0 Theater	
Auditorium	2880
Projection Booth	128
Concessions	128
Concessions Storage	192
Lobby w/ Ticket Booth	1600
General Storage	96
Manager Office	144
Employee Back Room	192
Janitorial	64
Restrooms	192

4.0 Administration	
Executive Sized Office	192
Manager Sized Office	128
Regular Sized Office	64
Bullpen Area	768
Copy / Work Room / Mailing	320
Employee Break Room	256
Staff Restrooms (single)	96
Conference Room	320
Reception	144

5.0 Collections	
Loading / Delivery Receiving Area	5120
Equipment Storage	400
Clean Collections Holding	4800
Dirty Collections Holding	4800
Collections Processing	4800
Collections Storage	20736
Crate Storage	9600
Workshop	1920

6.0 Service	
Mechanical	144
Electrical	144
Server Room	320
Fire Riser	96
Facility Equipment Storage	192
Underground Parking	0

7.0 Egress	
Visitory Elevator Bank	400
Freight Elevator	144
Fire Stairs	192
Main Staircase	256

	DNSF	DGSF	BGSF
All Departments Gross SF		182,980	
Factor: Dept. to Bldg.			1.40
<b>Grand totals</b>	<b>146,384</b>	<b>182,980</b>	<b>256,172</b>

Dimensions	
8	12
20	24
80	120
16	16
60	80
20	24
32	48
20	24
8	16
12	16
20	48
32	48
24	32
8	8
12	16
8	12
12	16
8	12
24	24
48	48
96	120
8	12
144	144
120	120
60	80
8	12
48	60
8	16
8	16
12	16
40	40
8	12
12	12
12	16
8	8
12	16
12	16
12	16
8	16
8	8
12	16
64	80
20	20
60	80
60	80
60	80
144	144
80	120
40	48
12	12
12	12
16	20
8	12
12	16
12	16
16	20
80	120
40	48

Catchment	#	NSF	Total NSF	NOTES
Security Area / Monitoring Station	1	72	72	By ticket desk
Lobby	1	10,800	10,800	Includes entry vestibule and ticket desks
Museum Store	1	6,000	6,000	Store to include museum merchandise as well as licensed movie merchandise
Museum Store Manager	1	64	64	Accessed through storage door - out of site
Museum Store Storage	1	632	632	Storage accessed by exterior and interior.
Cafe	1	1,458	1,458	Tables to expand into lobby
Cafe Storage / Kitchen	1	480	480	
Coatroom	1	118	118	Storage for ticket / help desks. Wheelchair storage
Restrooms	1	730	730	Single restrooms with share sink area
Resource Center	1	888	888	
Flexible Special Event Area	1	5,200	5,200	third floor with rooftop balcony to city view
Education Room	2	976	1,952	Accessed through resource center
Janitorial	1	112	112	
Employee Breakroom	1	220	220	
Employee Restrooms	2	70	140	Single use restroom
Employee Locker Rooms	2	150	300	
Departmental Net SF			<b>29,166</b>	
Factor: Net to Gross				<b>1.15</b>
Departmental Gross SF			<b>33,541</b>	

Exhibit / Programs	#	NSF	Total NSF	NOTES
Orientation Room	1	875	875	Part of permanent exhibits
Child's Area	1	5,300	5,300	First Floor: Parents can take children through or drop off - isolated for security
Temporary Exhibit	1	9,216	9,216	
Temporary Exhibit Shop	1	805	805	Shop open to atrium, has closed off storage with freight elevator access
Permanent Exhibits	1	28,000	28,000	5 exhibits which increase in scariness
Rotating Exhibits	1	16,000	16,000	3-4 exhibits
Staging Area	1	6,100	6,100	Floor 2: used for temporary and rotating exhibits
Restrooms (singles)	8	70	560	4 on floor 2, 4 on floor 3 (singles)
Medic	1	152	152	available in reliever zone on third floor
Reprive Zones	1	1,892	1,892	hallways with stair access and restrooms + room on floor 3
Departmental Net SF			<b>68,900</b>	
Factor: Net to Gross				<b>1.15</b>
Departmental Gross SF			<b>79,235</b>	

Theater	#	NSF	Total NSF	NOTES
Auditorium	2	3,024	6,048	144 seats per auditorium - top down seating with imax pit
Projection Booth	2	128	256	accessible on half floor
Concessions	1	212	212	
Storage	1	834	834	2 storage space. One shares with concessions
Lobby	1	1,950	1,950	Access to museum lobby. Ticket booth included by entry
Manager Office	1	200	200	
Employee Back Room	1	306	306	
Janitorial	1	168	168	
Restrooms	1	418	418	Single stall restrooms with shared sink space
Departmental Net SF			<b>10,392</b>	
Factor: Net to Gross				<b>1.15</b>
Departmental Gross SF			<b>11,951</b>	

The class focused on the work *Problem Seeking* by William Pena and consisted of three sections: functional programming, space programming, and gaming. The functional program allowed me to take my chosen site and project and evaluate them through function, form, economy, and time (Peña & Parshall, 2012). Through these four sections and their subtopics, I was able to create problem statements for my project that I was able to take with me and adjust in the early stages of the final study project. On page 28 (green) are a few examples of functional programming developed

Administration	#	NSF	Total NSF	NOTES
Executive Sized Office	2	228	456	Includes offices for: CEO and Executive Director
Manager Sized Office	4	169	676	Includes offices for: Office Manager, Bookkeeper, Administration Director, Facility Manager Office
Bullpen Area	1	654	654	16 desks
Copy / Work Room / Mailing	1	364	364	
Employee Break Room	1	334	334	
Staff Restrooms (single)	2	77	154	
Conference Room	2	315	630	
Reception	1	328	328	100 + 10 per waiting
Storage	1	150	150	
Departmental Net SF			<b>3,746</b>	
Factor: Net to Gross				<b>1.25</b>
Departmental Gross SF			<b>4,683</b>	

Collections	#	NSF	Total NSF	NOTES
Loading / Delivery Receiving Area	1	3,000	3,000	Includes office for Warehouse Manager
Equipment Storage	1	961	961	
Clean Collections Holding	1	4,000	4,000	
Dirty Collections Holding	1	4,000	4,000	
Collections Processing	1	4,000	4,000	
Collections Storage	1	12,000	12,000	
Crate Storage	1	4,000	4,000	
Workshop	1	2,500	2,500	
Curator / Collection Manager Office	1	356	356	Accessible through workshop
Departmental Net SF			<b>34,817</b>	
Factor: Net to Gross				<b>1.25</b>
Departmental Gross SF			<b>43,521</b>	

Service	#	NSF	Total NSF	NOTES
Mechanical	2	144	288	One in sub-floor, one on third floor
Electrical	2	144	288	One in sub-floor, one on third floor
Server Room	2	320	640	One in sub-floor, one on third floor
Fire Riser	2	96	192	Need access from first floor
Facility Equipment Storage	1	192	192	
Departmental Net SF			<b>1,600</b>	
Factor: Net to Gross				<b>1.10</b>
Departmental Gross SF			<b>1,760</b>	

Space Program from early stages of design. through the problem seeking matrix. Space programming was essential to the success of the project. Using the previously mentioned precedents along with consultation with my uncle, the director of Frontier Texas in Abilene, and Dr. Bieber, a previous curator for the Tate Modern and the Fresno Metropolitan, I was able to determine the spaces needed, the number of these spaces, and the rough size of these spaces. The image above and to the left are space programming that was completed during the first stage of project development. They are not updated, final numbers as a professional space program would be, but are rough estimates that I was able to look back upon during the project. The estimated grand total of the building was 256,172 square feet and the final number ended up being 243, 896 square feet.





The most invaluable aspect I've gained from the class is gaming. Using the spaces that were programmed and quantified during the previous section, space programming, I was able to create these gaming diagrams, more commonly thought of as parti diagrams. On page 30 is an example of a three level game that was completed in the Architectural Programming class. Seen on page 31 are four games I developed during the project's initial stages of the Architectural Design IV class.

I had experimented with different relationships of spaces, but ultimately was satisfied with certain locations. The theater, that would ultimately be two levels high, was always on the Southern

corner, adjacent to the Dallas World Aquarium. The collections were always stored on the basement level so that there would be easy access to a loading dock that would be less apparent in the building facades. I experimented with having a different number of cores and focusing on different architectural ideas as concepts. A concept I had picked up from my trip to D.C. that was most present in the International Spy Museum was the idea of a top down pathway throughout the museum. That idea stuck with me throughout the project and is a primary factor in how guests are able to circulate and experience the exhibits.

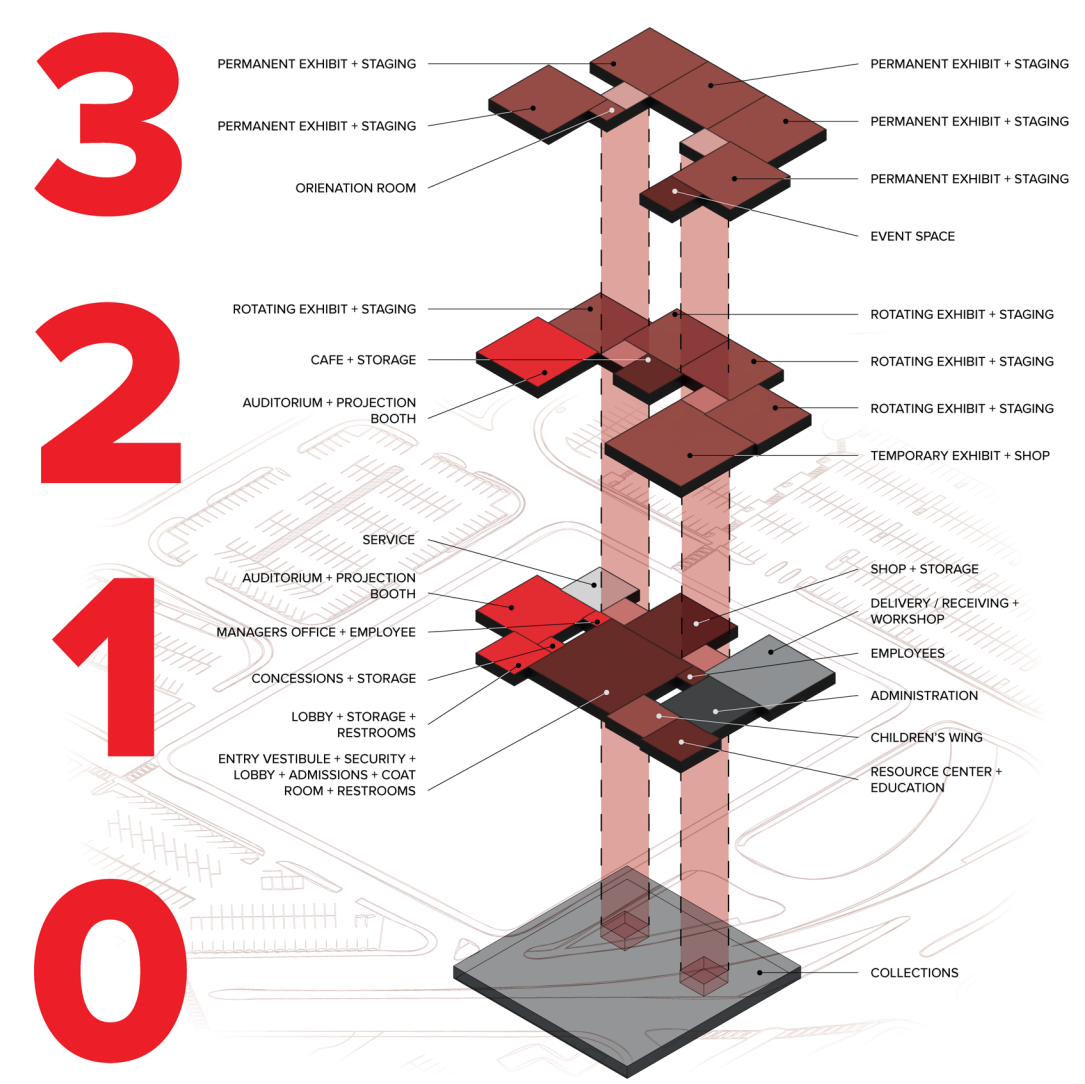
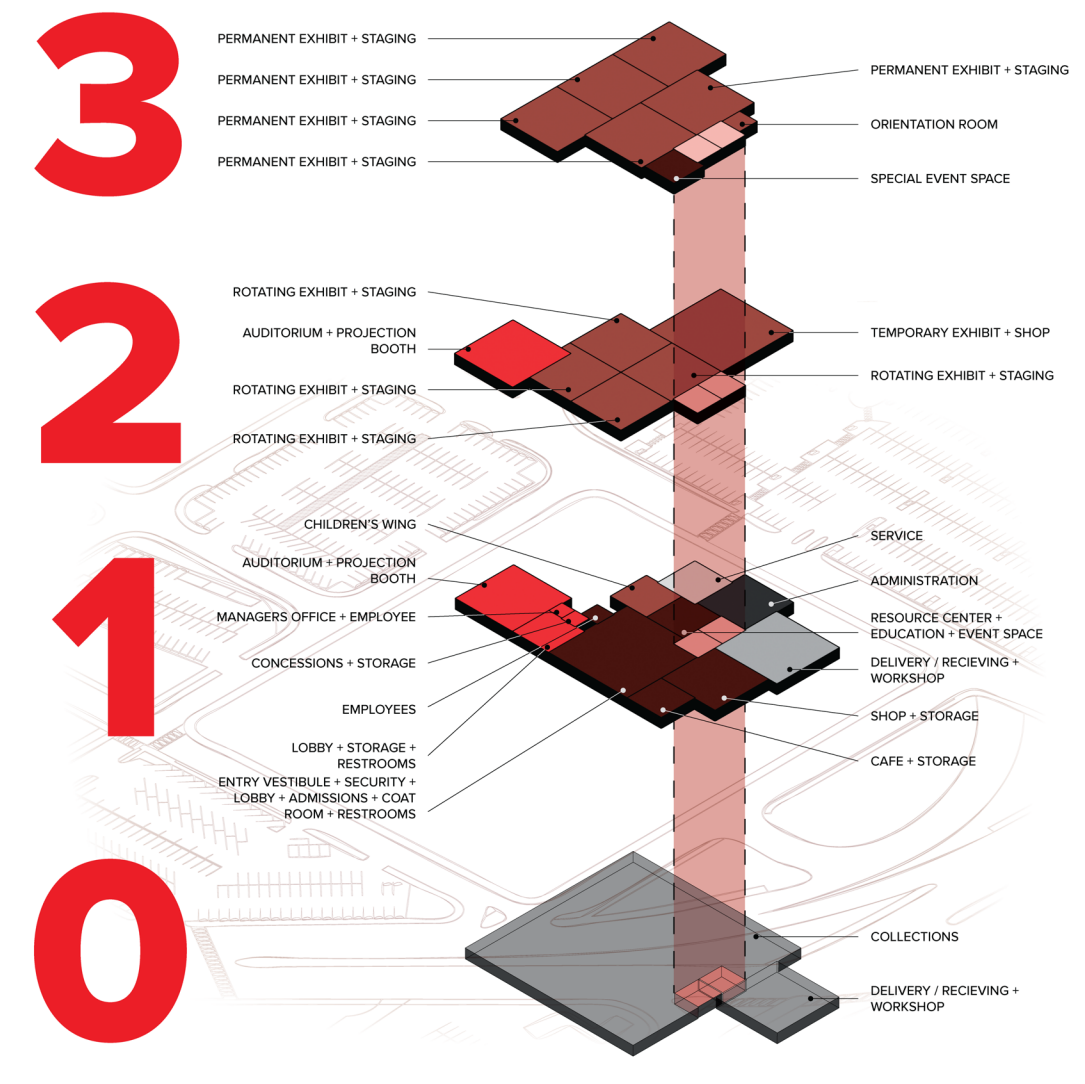
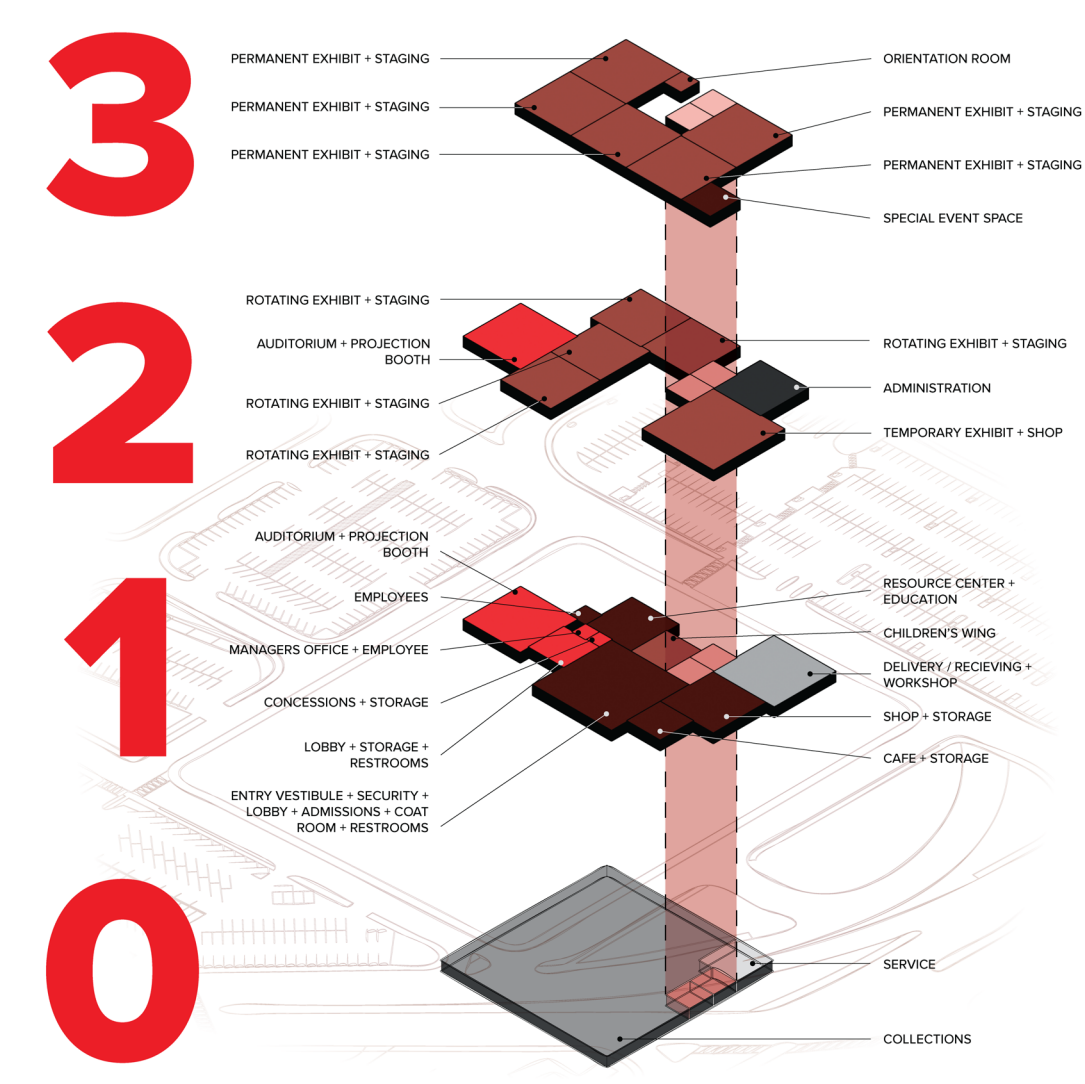
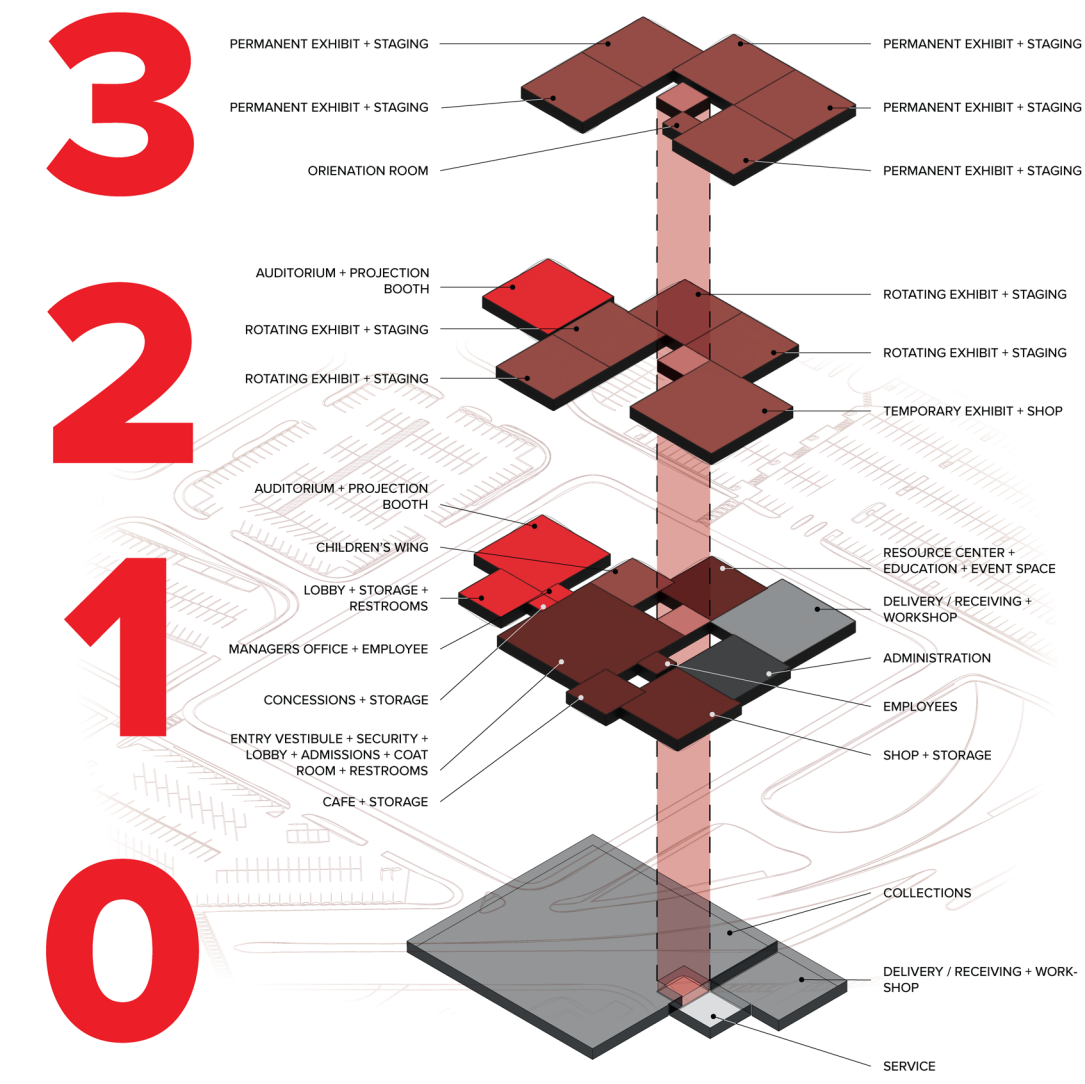
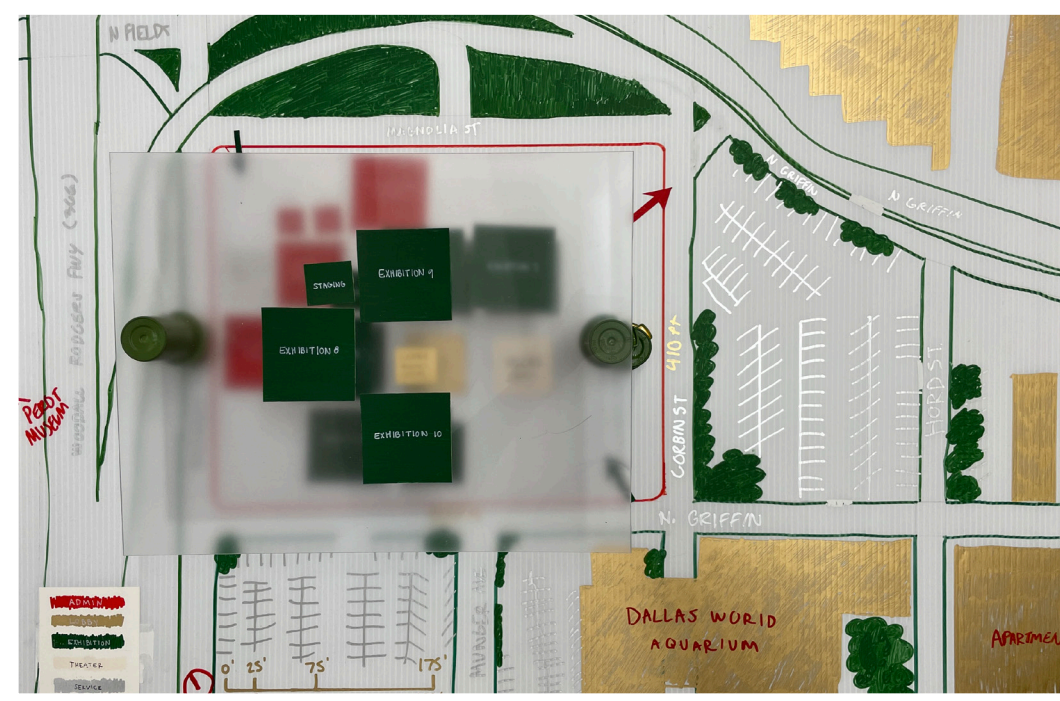

# 3

# 2

# 1

# B

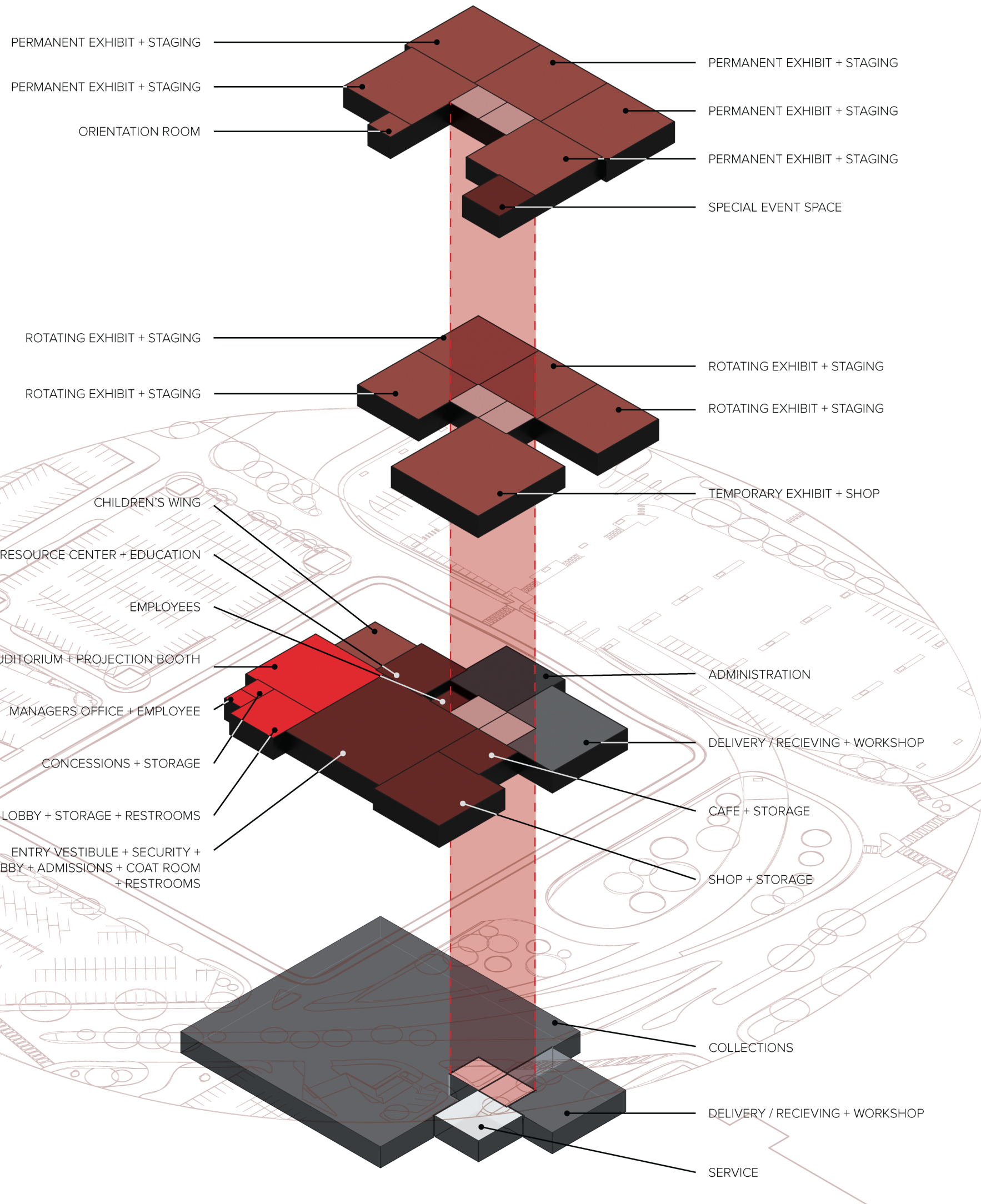

<b>ADMINISTRATIVE SEPARATION</b>	Will the administration have a separate area from the public so that neither interfere with each other?	5
<b>ACTIVITY GROUPING</b>	Are activities properly grouped with each other?	5
<b>SEQUENTIAL FLOW</b>	Opportunity for permanent exhibits to move in a sequential flow according to scariness	5
<b>MIXED FLOW</b>	Opportunity for flow of visitors between areas of the museum	5
<b>ENVIRONMENTAL ENHANCEMENTS</b>	Opportunity for environmental enhancements that connect and integrate with the building	4
<b>CHARACTER OPPORTUNITY</b>	Does the design provide the opportunity for a distinct exterior character?	4
<b>IMMERSION</b>	Opportunity for an immersive experience for the visitor	5
<b>UTILIZATION</b>	Is there opportunity for proper utilization for things such as sunlight, views, avoidance of sound, etc.?	4
<b>EXPANSIBILITY</b>	Is there opportunity for expansion?	4
<b>FLEXIBILITY</b>	Is there opportunity for flexibility?	5
<b>Total Points</b>		<b>46 / 50</b>

Before gaming, a set of criteria is established to guide the selection of the winning game. Throughout my project, I utilized problem statements developed during the functional programming stage. These statements originated from the Architectural Programming class and were modified and adapted to reflect any changes between the class and the gaming stage of the project. The criteria presented above served as the basis for evaluating the “winning” game for this project. While it underwent further refinement during the schematic stage, it provided a solid foundation to keep me focused during the development of project schematics. Adjacent is a concept site plan created prior to and adjusted after the game selection.

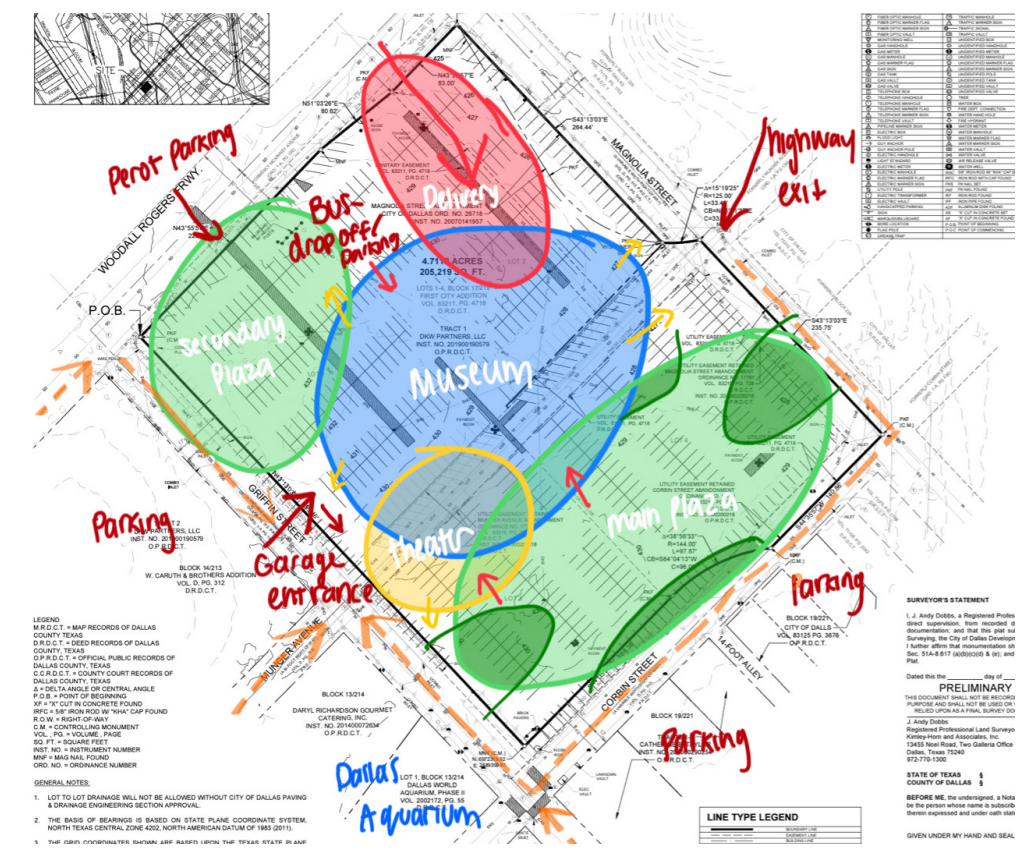

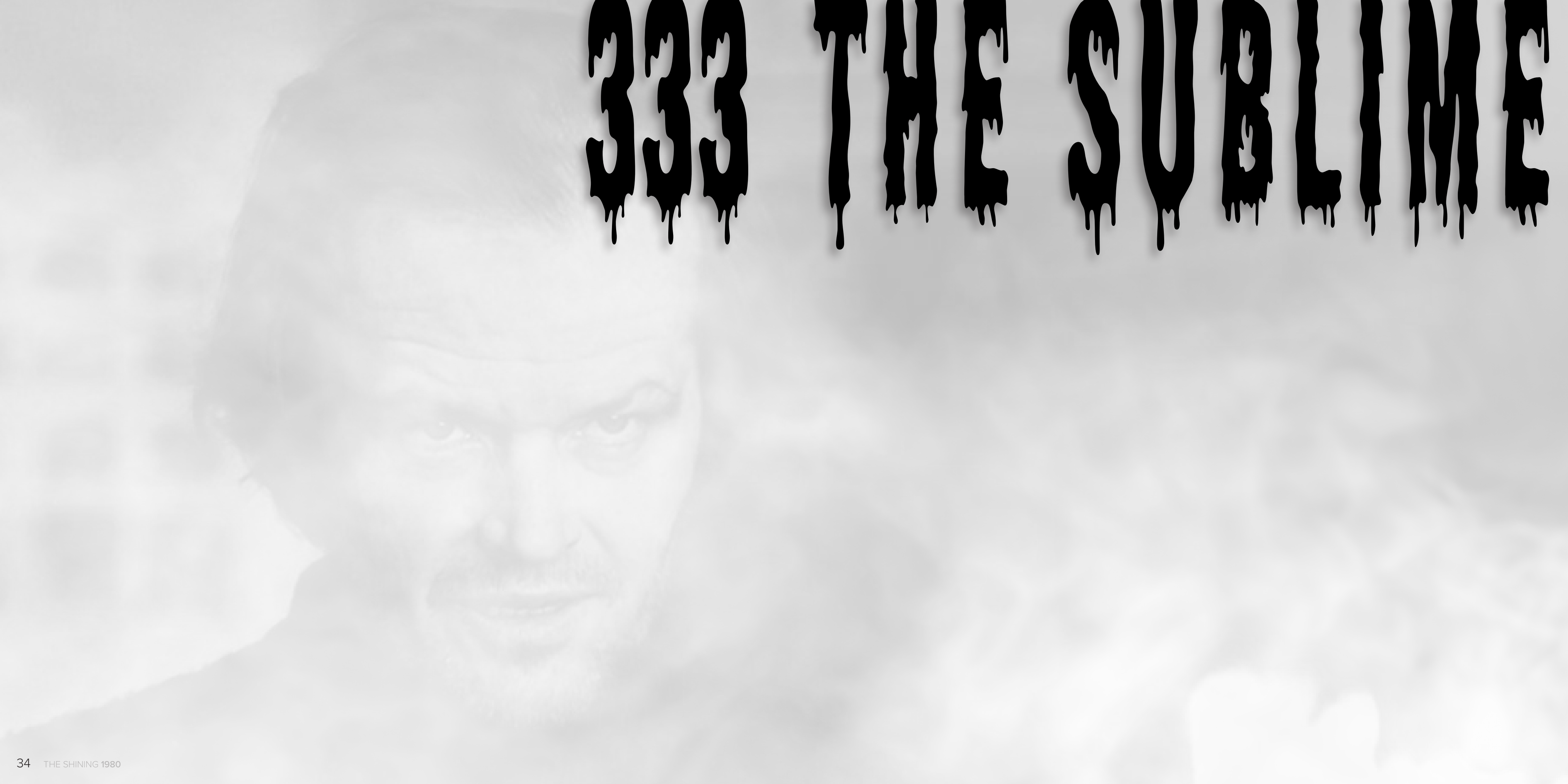

# 333 THE SUBLIME

# HORROR IN ARCHITECTURE



BY JOSHUA COMAROFF + ONG KER-SHING

Originally written in 2013, the book *Horror in Architecture* by Joshua Comaroff and Ong Ker-Shing of the architectural practice Lekker focuses on the exploration of how horror genre tropes manifest in the built environment (Comaroff & Ker-Shing, 2013). Even with only being a mere eleven years old, the authors were aware of the “so-called horror renaissance” of the past ten years and created a new edition of this book “to make clear why architecture matters” and explain “how interesting times make interesting matters” (Comaroff & Ker-Shing, 2024, ix,x).

As previously mentioned, horror continues to evolve with society and “the past decade has been one of global upheaval, in politics and culture” (Comaroff & Ker-Shing, 2024, x). Comaroff and Ker-Shing introduce the sublime horror, something that opposes the superficiality of beauty (Comaroff & Ker-Shing, 2013).

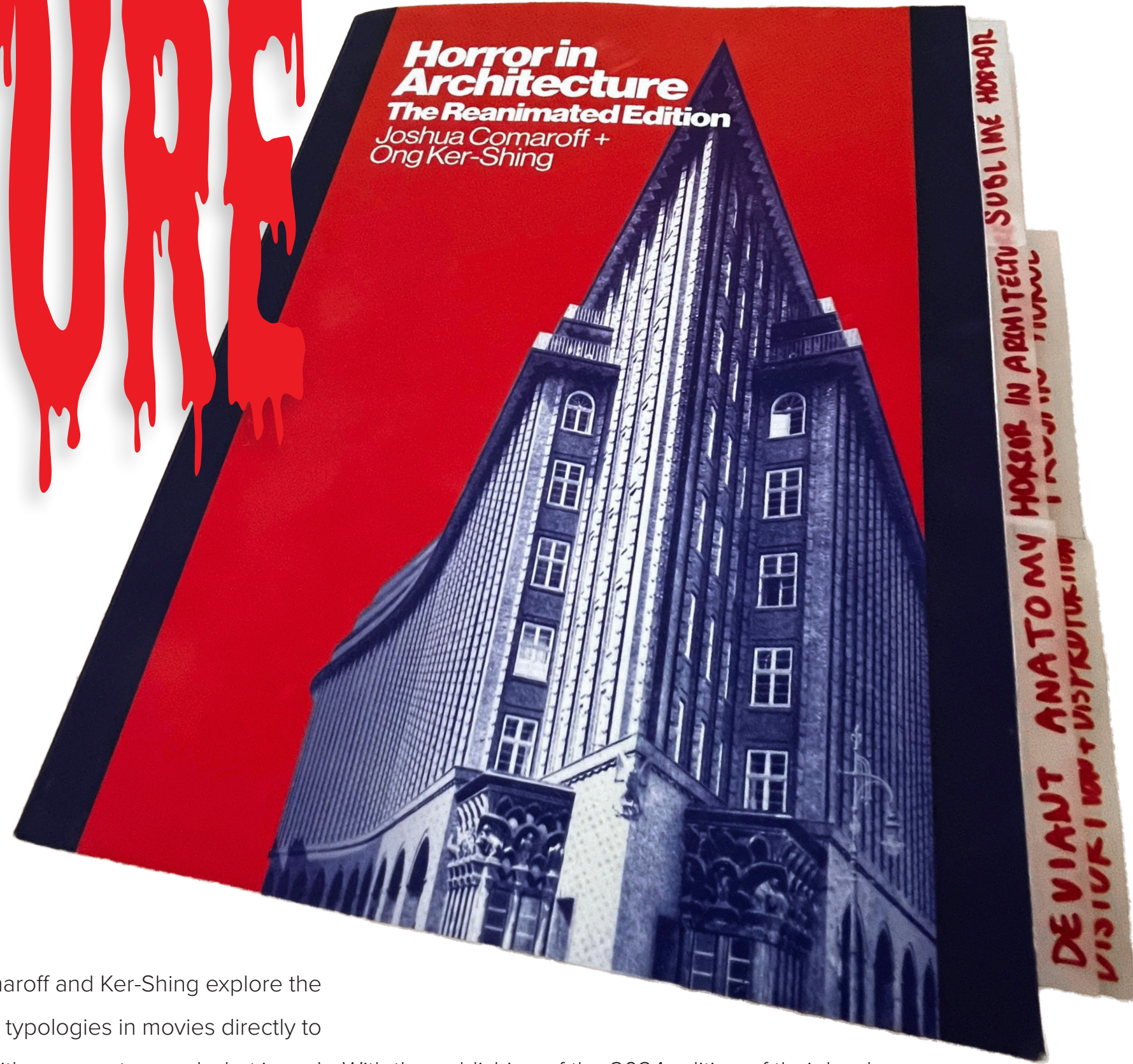

Within this book, Comaroff and Ker-Shing explore the connections of horror typologies in movies directly to architectural works, with commentary and what is and what can become of these tropes in an architectural context. These typologies include doubles & clones, exquisite corpse & ungrammatical body, partially and mostly dead, reiteration and reflexivity, incontinent object, trojan horse, homunculism & gigantism, solidarity & stereotomy, and distortion and disproportion (Comaroff & Ker-Shing, 2013).

With the publishing of the 2024 edition of their book, new typologies of blobs, puppets, insurgent natures, and displacement were introduced (Comaroff & Ker-Shing, 2024). These typologies were used as a foundation for the Horrified project and were used as guidance for many design decisions, especially when considering the overall experience the museum guest would be expecting.

# SCHEMATA

## Doubles and Clones

## Exquisite Corpse and Ungrammatical Body

## Partially and Mostly Dead

## Reiteration and Reflexivity

## Incontinent Object

## Trojan Horse

## Homunculism and Gigantism

## Solidity and Stereotomy

## Distortion and Disproportion

## Blobs

## Puppets

## Insurgent Nature

## Displacement



**Tatterdemalion:** “A complete body, but an incomplete self.” (Comaroff & Ker-Shing, 2013, 75)

*Cadavre exquis*  
Andre Breton, Jacqueline Lamba, and Yves Tanguy  
National Galleries of Scotland



**Unheimlich:** “The conflation of that which is intimate and that which is foreign in the same entity.” (Comaroff & Ker-Shing, 2013, 142)

*Anatomy from 'Eldorado'*  
Eric Tabuchi



**Deformity** “The morphology of an object, or piece thereof, is contrary to expectation.” (Comaroff & Ker-Shing, 2013, 192)

*Lewis House, Ohio*  
Frank Gehry

## EXQUISITE CORPSE

Exquisite Corpse was chosen for the parti and programming section of this book. It “refers to a parlor game associated with Andre Breton and the Parisian surrealists” (Comaroff & Ker-Shing, 2024, 45). It was the disjunctive aesthetics that related to Shelley’s Frankenstein and therefore reminded me of the parti portion of the project (Comaroff & Ker-Shing, 2024, 47). It represents the project in its most disconnected stage, where ideas are not realized and pieces of the project are strewn together without completion.

## THE SUBLIME

The Sublime was chosen for the *Horror in Architecture* section of this book. The sublime itself is not listed as a typology according to the the book, but in the introduction makes it clear that the sublime, “the strongest emotion which the mind is capable of feeling,” (Des Pres, 1983, 135) is important not only to Horror, but to the book as well. The original source of this investigation into the sublime, Edmund Burke, states “indeed terror is in all cases, whatsoever, either more openly or latently the ruling principle of the sublime” (Burke, 1968, 58). As the sublime is an important concept throughout *Horror in Architecture*, it was fitting that it was also the title for this section.

## THE BLOB

The Blob was chosen for the exteriors section of this book. In the original 2013 publishing of this book, blob was not listed as an original typology, but rather in the post-script under the idea of formlessness. In the 2024 edition of *Horror in Architecture*, blob was added as an official typology and was discussed in terms of two different types of blob, one being “the curvilinear, free-form version” (Comaroff & Ker-Shing, 2024, 155), that is present on the exterior of the museum building, and a second as “a variant of the very large building, or ‘megastructure’” (Comaroff & Ker-Shing, 2024, 155) that can be thought of as the ‘back area’ of a large structure; a blob of programmed spaces. The literal blob is the focus of this section.

## TROJAN HORSE

Trojan Horse was chosen for the schematic section of the book as it is the primary typology concept that is used throughout the project. As Comaroff and Ker-Shing describe it, the trojan horse is “a dissociation or rift occurs between the contents of a building and its expression” (Comaroff & Ker-Shing, 2013, 142), which can sometimes be described as “unheimlich” or “the conflation of that which is intimate and that which is foreign in the same entity” (Comaroff & Ker-Shing, 2013, 142). Something that the authors discuss as a negative in modern architecture is the lack of surprise and how “confusion among typologies continues to arise from the failure to give them an independent expression” (Comaroff & Ker-Shing, 2013, 157). The trojan horse used within the Horror Movie Museum is an interpretation of this concept.

## HOMUNCULSIM

Homunculism was chosen for the details section of the book. The homunculus “includes any miniature that copies a normally-sized precedent” (Comaroff & Ker-Shing, 2013, 161) and “is able to exist somewhere between its building and mode; that is, between the object and its representation” (Comaroff & Ker-Shing, 2013, 165). Homunculism was chosen as the title for the section on the details of the project because these are pieces that make the project, but would not be visible at the scale or representation of many of the provided drawings. In the case of this project, these are primarily ideas that were prominent to the success of the project but were ultimately unable to be visually represented to the scale that would do them justice. These are the miniature representations of the project as a whole.

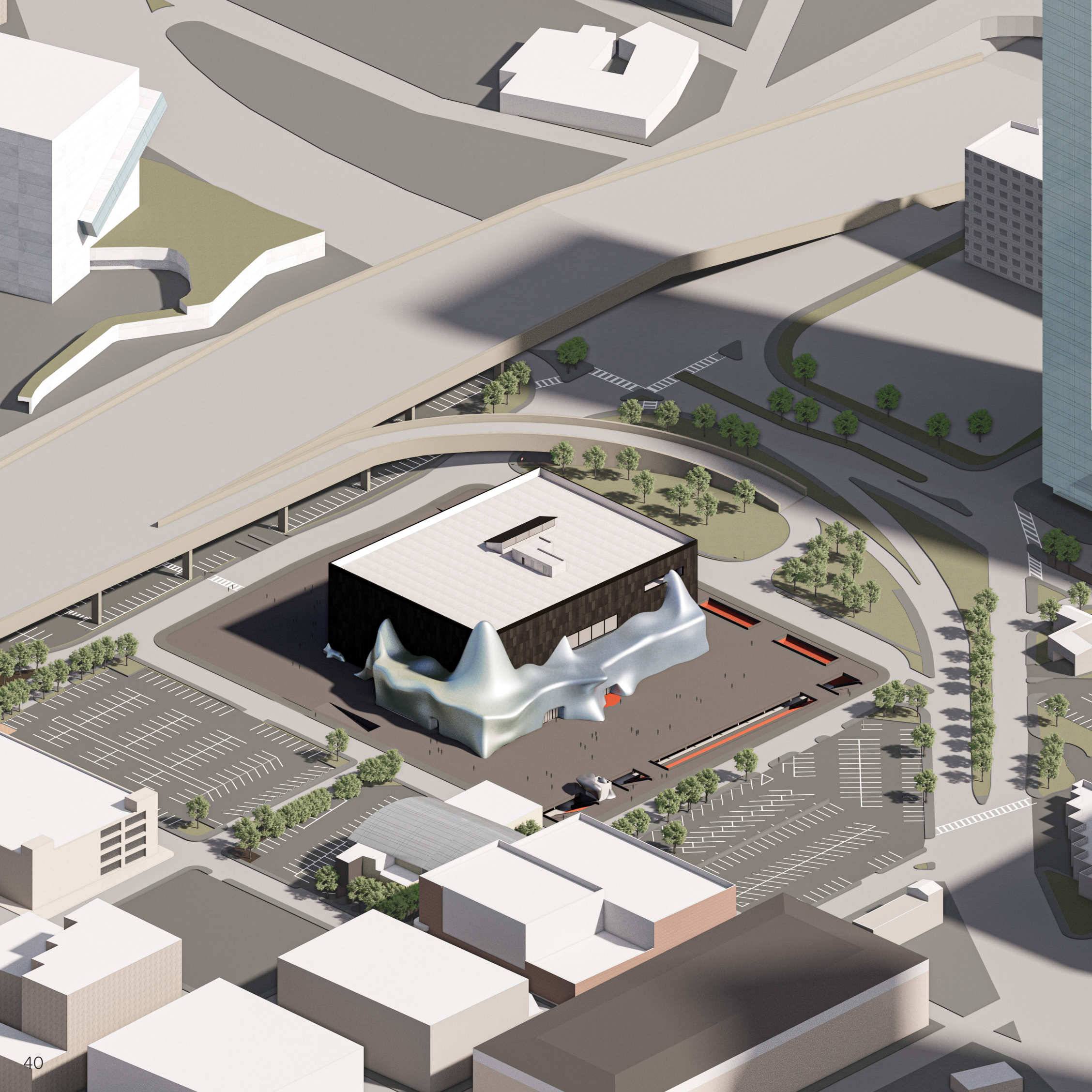

The project idea was originally based on the idea of the Trojan Horse, with the *Horror in Architecture* typologies to be used as the deciding factor of the exterior elements, while the interior was clean and, in a way, traditional. There was to be no idea what lies within when looking on the outside of the building. A second concept behind the Trojan Horse became clear as the project progressed; that something orthogonal and clean contained the histories of the messiest movie genre. While this idea is still prevalent in the final product, the distinction between the inside and outside became muddled with the introduction of the 'blob.' In *Horror in Architecture*, Comaroff and Ker-Shing describe the blob as two possible versions. The first being the "literal blob," with a free-form shape and the second being the disorder of the megastructure (Comaroff & Ker-Shing, 2024, 155). The exterior skin, sometimes referred to as the 'blob,' is the former type of blob. It is a system of Zahner Engineered Perforated Panels (ZEPPS) that contradict the clean facade of the building. The idea of the skin was introduced as an experiment with inflatable structures, an evolutionary phase of the architectural blob in the 1970s that will be discussed later in the book (Comaroff & Ker-Shing, 2024). It became something ossified; something that appeared to be engulfing the building as a whole while simultaneously representing the typologies of distortion and reflexivity (Comaroff & Ker-Shing, 2013). The primary goal of the skin in the Horror Movie Museum is to appear to be intruding on, or even engulfing, the existing prism of the museum, completely covering the small extension containing the theater and museum lobbies. Despite the unconventional nature of it, development of this blob is not random, but is strictly designed.



W  
H  
E  
R  
E  
D  
O  
B

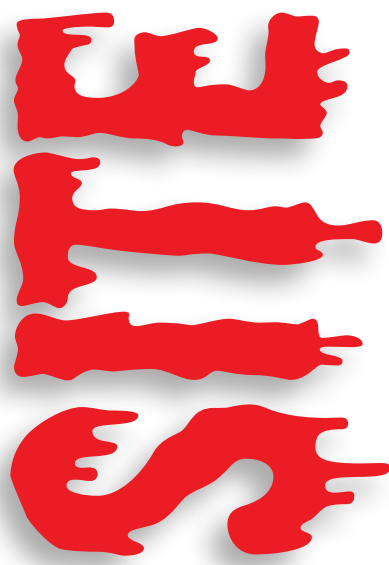

The site serves as the initial immersion point into the museum experience as soon as visitors arrive. Upon parking in the underground garage, guests can ascend via the plaza stairs or utilize the blob-covered elevator located on the Western side of the site. The primary plaza is situated to the South, while the secondary plaza is to the North. This dual-plaza setup ensures accessibility from both sides of the building, accommodating visitors who arrive via shared parking with the Perot Museum beneath the highway.

Within each plaza, seated planters are strategically placed, some purely for visual impact, while others offer seating and functional use. These planters feature carefully selected flora, chosen not only for their red hues reminiscent of blood but also for their ability to evoke fear. The plant selection includes species that naturally induce a sense of unease, with non-native species placed to enhance the eerie atmosphere.

Complementing the planters are sculptures, ranging from spooky trees to large spiders reminiscent of those at the Guggenheim in Bilbao. Given the constraints of the parking garage underneath, the planting of real trees is limited to specific areas. However, elevated planting areas provide opportunities for other vegetation to flourish, contributing to the overall ambience of the site.



44 ROOF PLAN SITE



Doll's Eye / White Baneberry  
*Actaea Pachypoda*  
oaklandcountyblob.com | Jonathan Schechter



Jackal Food / Jakkalskos  
*Hynora Africana*  
flickr.com | Tom Ballinger



Japanese Blood Grass / Red Baron  
*Imperata Cylindrica*  
gardenista.com | unknown



Devil's Fingers / Octopus Stinkhorn  
*Clathrus Archeri*  
istockphoto.com | albydetweede



Stinking Corpse Lily  
*Rafflesia Arnoldii*  
medium.com | lazy.penguin



Red-Tip Photinia / Christmas Berry  
*Photinia x Fraseri*  
plants.ces.ncsu.edu | Jim Robbins



Snapdragon / Dragon Flowers  
*Antirrhinum*  
gardenknowhow.com | nahhan

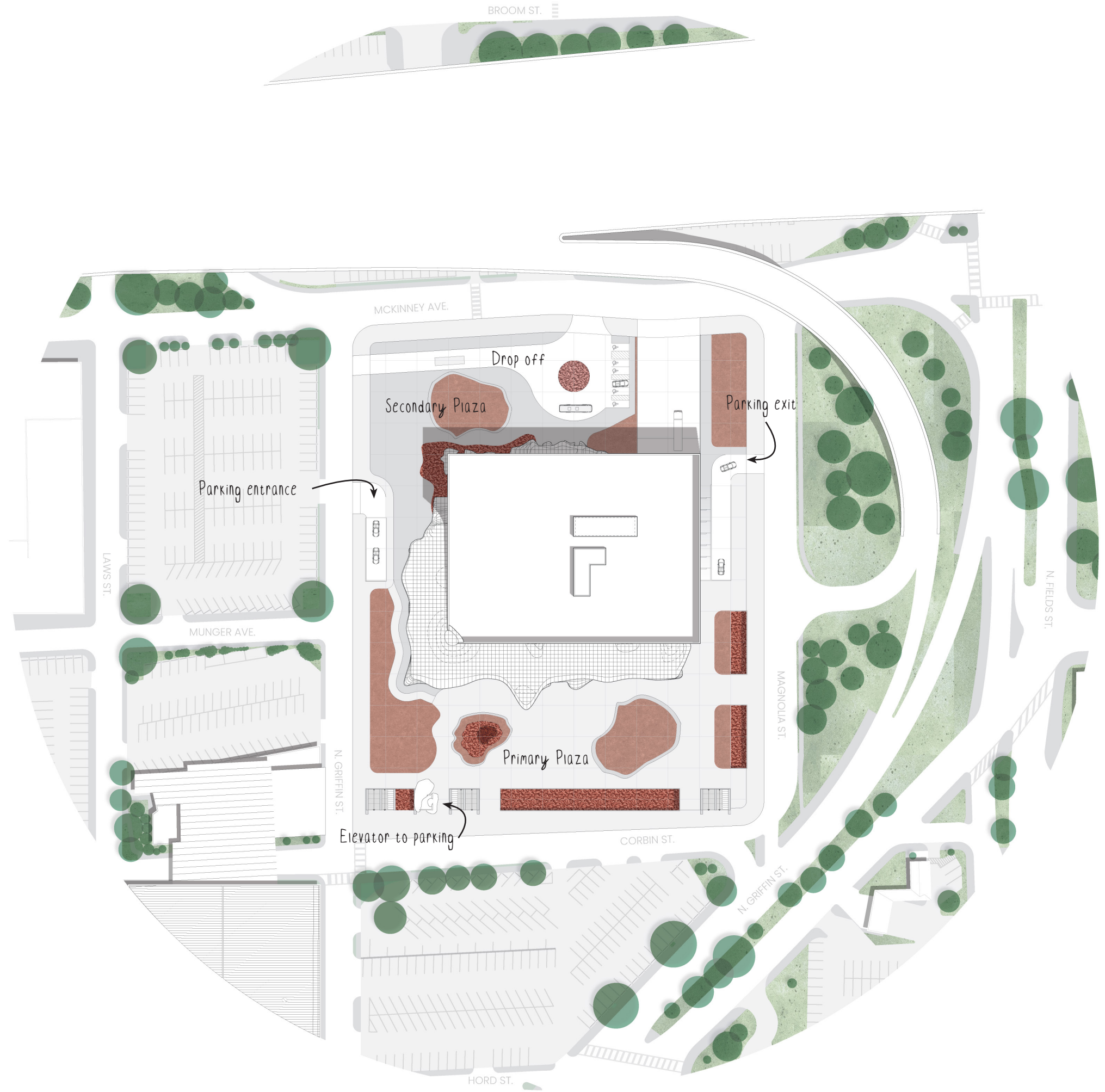



# INFLATABLE SKIN

As previously discussed, the architectural blob underwent various stages of evolution, notably during the Archigram movement of the 1960s, characterized by “the essence of the blob is this resistance to fixity or legibility” (Comaroff & Ker-Shing, 2024, 157), and the emergence of the inflatable movement in the 1970s, where the blob found architectural prominence. Upon encountering this revelation in the book released in 2024, I was intrigued by the connection between the blob and inflatables, which ultimately inspired the creation of the skin in this project.

In a sketch completed for an Art and Architectural History course taught by Dr. Bieber in the Fall of 2023, I explored the history of inflatable art and architecture. The assignment prompted me to sketch and design my own inflatable structure, drawing upon influences from Frank Gehry’s works, particularly the distortion evident in buildings like the Lewis House

and the Museum of Pop Culture. Motivated by these inspirations, I envisioned the inflatable skin as the primary entrance to the museum, tying it back to the concepts explored in the inflatable class.

The subsequent development of the skin, as depicted in the steps detailed on pages 46 and 47, involved utilizing Rhino 8 software. I began by creating the basic prism of the museum and the lobby extension, marking planned windows and openings that would interact with the skin. Employing a cage edit technique, I manipulated the structure, adjusting 19 points on the ‘x’ axis, 13 on the ‘y’ axis, and 6 on the ‘z’ axis. This process aligned with the project grid, consisting of squares measuring 32 feet, with adjustments made in four-foot intervals. Fine-tuning involved incremental adjustments, ranging from four feet to as low as two feet, ensuring precise alignment with the overall design.

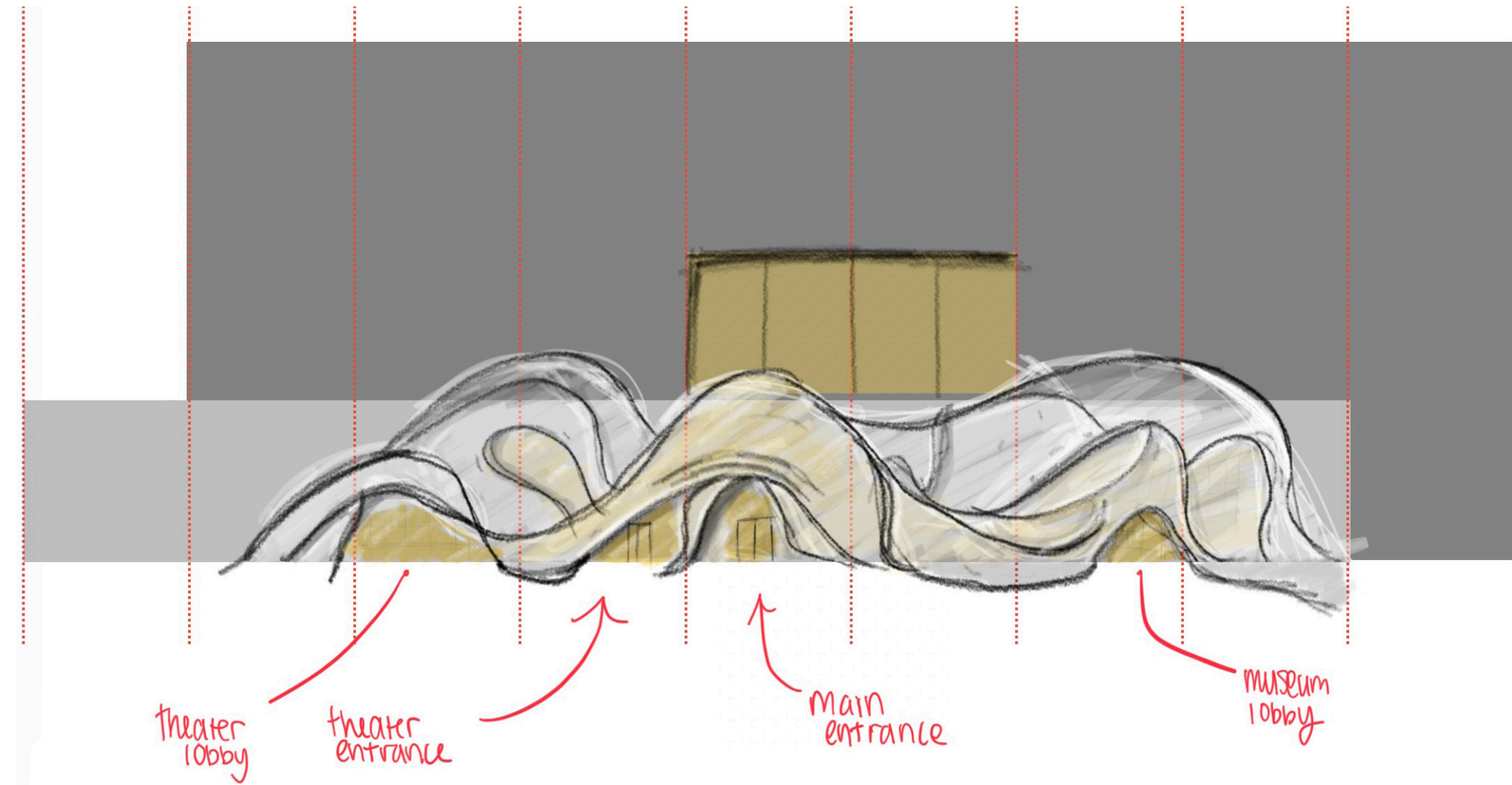
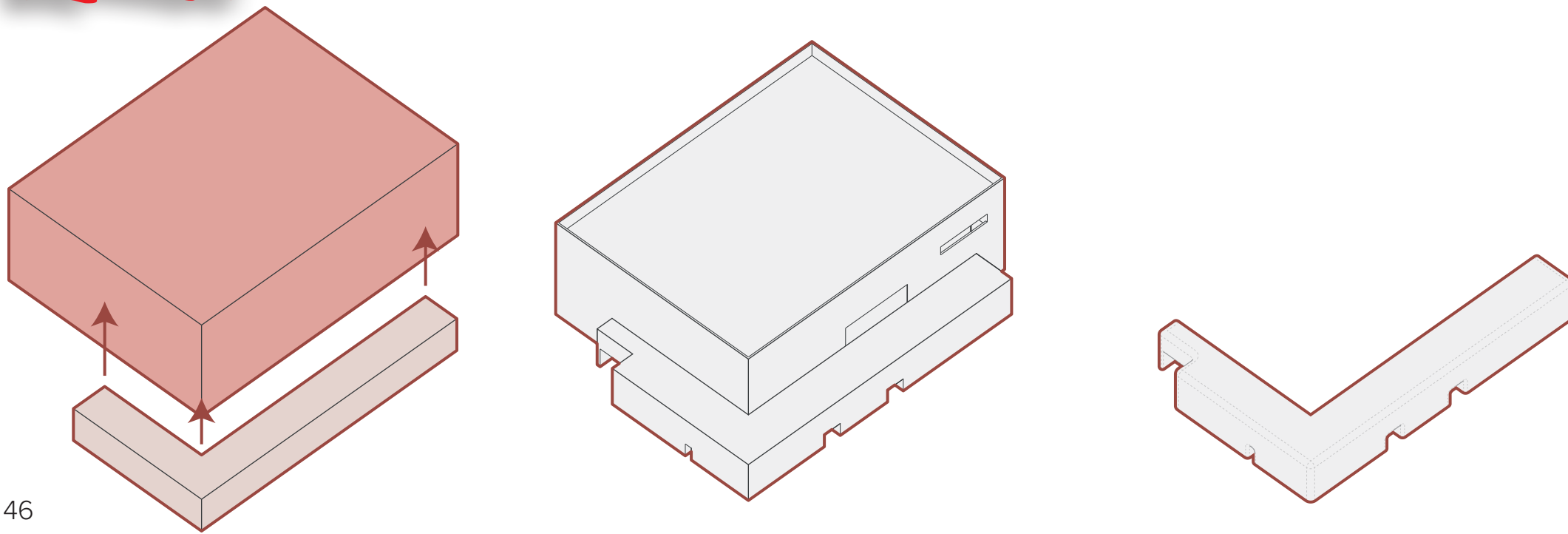

Starting from step five, the process involves crafting the metal panels designated for the skin material. Initially, contour lines are generated at four-foot intervals along the x, y, and z axes. These contours are then fine-tuned to achieve the desired panel shapes. The ultimate skin panels conform to the 4x4 foot grid established by these contours, although their dimensions may vary. Utilizing the ZEPPS and Drop & Lock systems by Zahner, the panels are shaped into distinct and customized non-parabolic forms.



The Getty Center  
Richard Meier, 1997  
Los Angeles, California



Heydar Aliyev Center  
Zaha Hadid Architects, 2012  
Baku, Azerbaijan

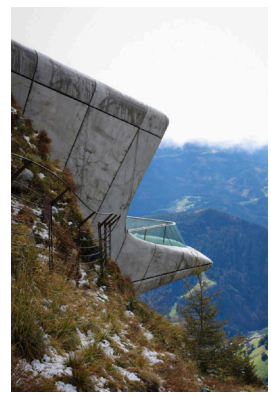

Messner Mountain Museum  
Zaha Hadid Architects, 2015  
Kronplatz, Italy

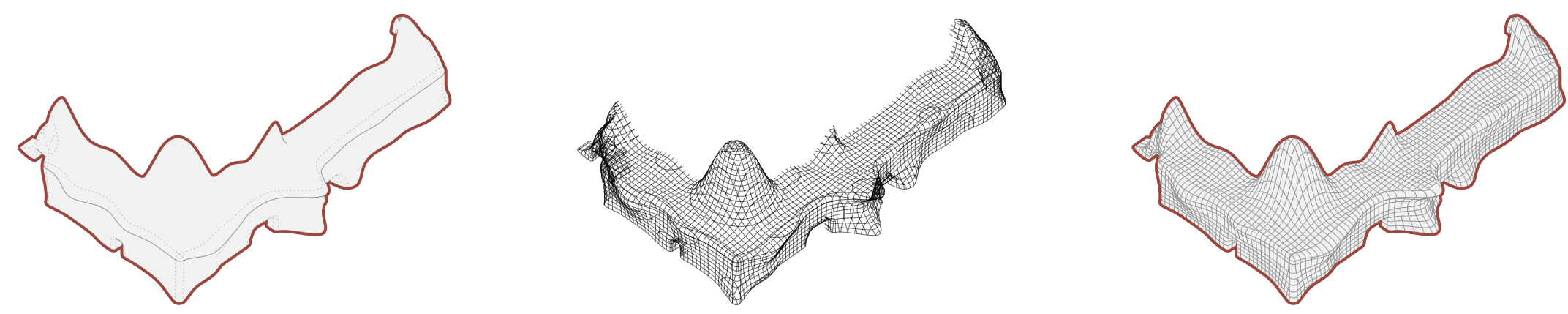



PARAPET 88'-0"

ROOF 80'-0"

FLOOR 04 56'-0"

FLOOR 03 32'-0"

FLOOR 02 16'-0"

FLOOR 01 0'-0"

FLOOR B -16'-0"



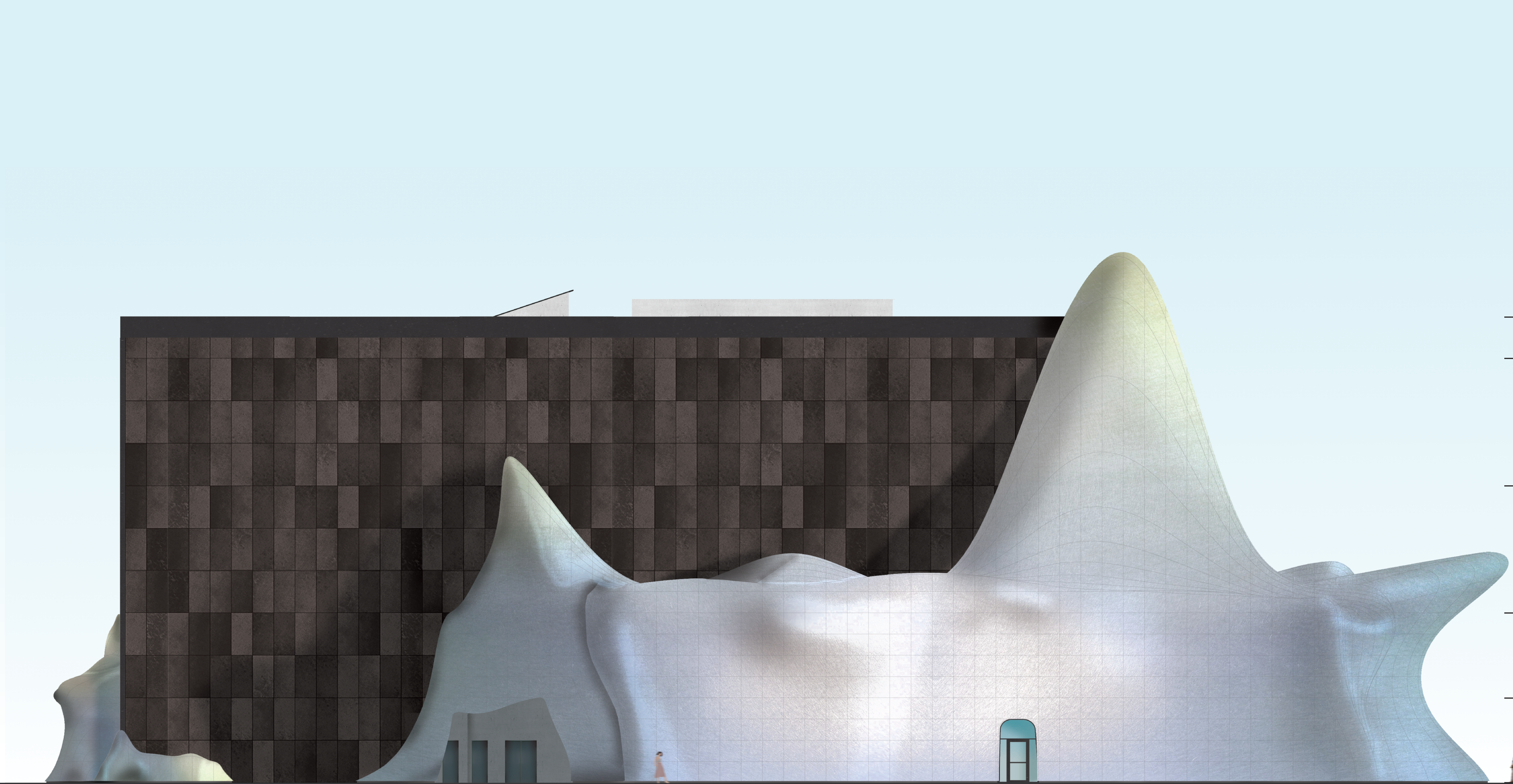

PARAPET 88'-0"

ROOF 80'-0"

FLOOR 04 56'-0"

FLOOR 03 32'-0"

FLOOR 02 16'-0"

FLOOR 01 0'-0"

FLOOR B -16'-0"



## LED ALTERNATE FACADES

The exterior cladding of the prism is a Drop & Lock system by Zahner, or at least it appears that way. The Southeast and Southwest facades are actually LED screens, while the Northeast and Northwest facades are true metal panel systems. The LED screens serve to act as an interactive element with guests and passerbyers. They can present ads, information, or creepy images

to entice potential visitors. With technology continuing to evolve, there is the possibility for the introduction of AI through the use of exterior cameras, moving images around as people walk by. When not in use for any specific purpose, the screens will be mimicking the solanum steel image of the true metal panel system.

### SPHERE

LAS VEGAS, NEVADA / POPULOUS



- Dynamic shell that displays 1.2 million LED pucks.
- More than 400 LED mega panels.
- 16k resolution, 9-millimeter pixel pitch screen.
- 516 feet wide and 366 feet tall.

(Populous)

### AT&T DISCOVERY DISTRICT

DALLAS, TEXAS / GENSLER

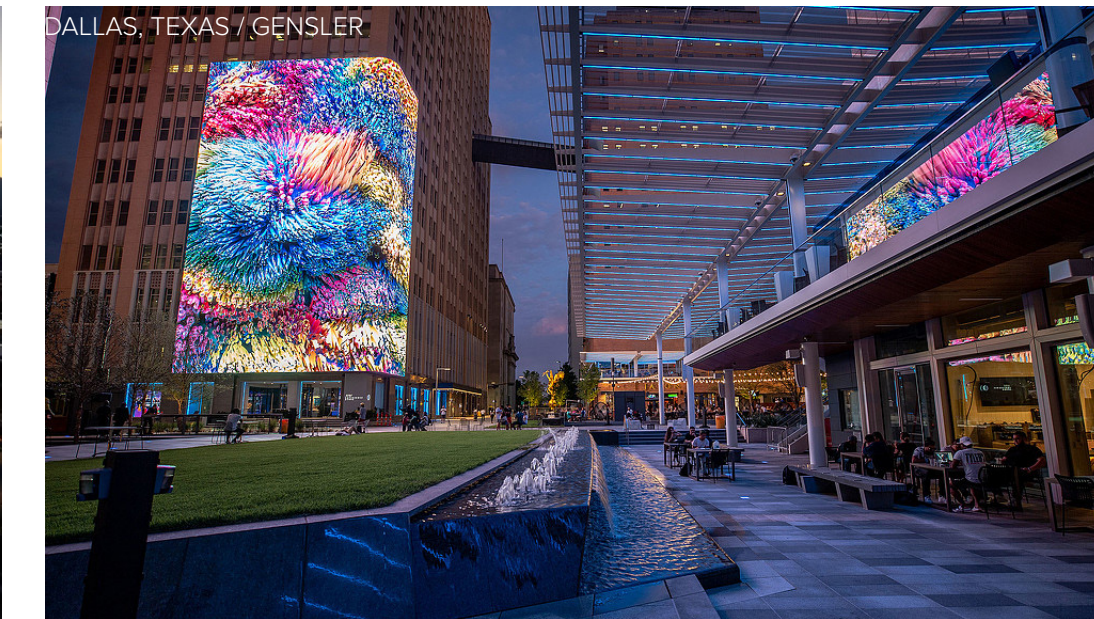

- 140k sqft of fully connected and immersive digital platforms
- 104 ft. tall and 90 feet wide media wall, one of the largest in the U.S.
- 120+ million LED pixels capable of operating in unison via integrated CMS
- 48+ hours of bespoke, artistic content

(Gensler)

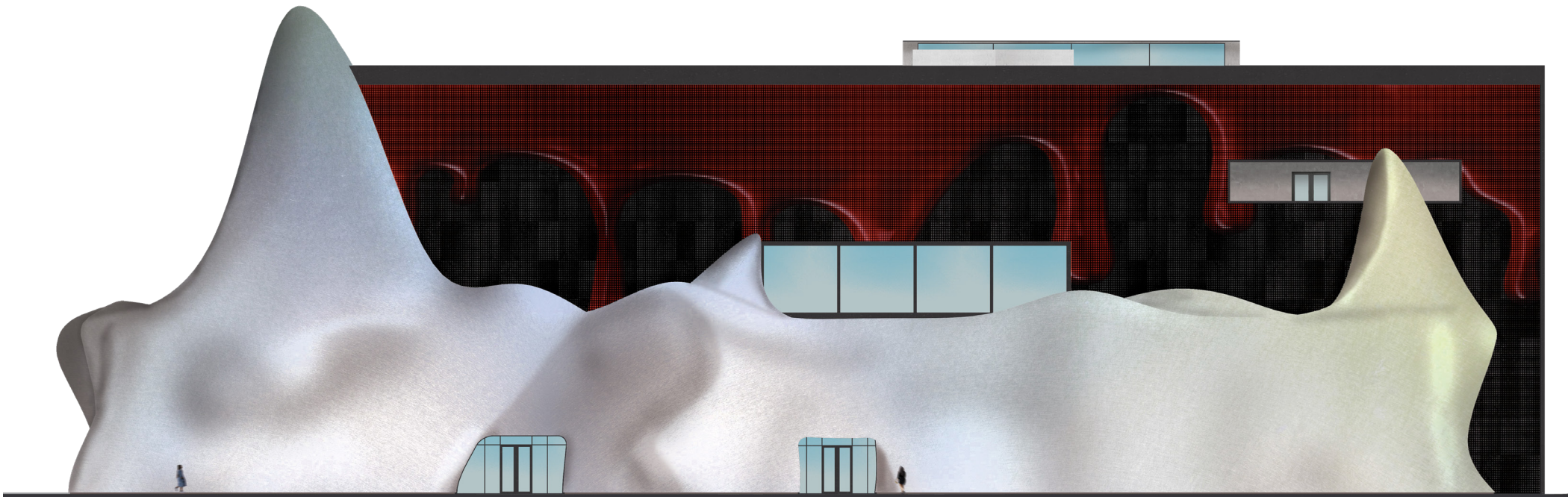



PARAPET 88'-0"

ROOF 80'-0"

FLOOR 04 56'-0"

FLOOR 03 32'-0"

FLOOR 02 16'-0"

FLOOR 01 0'-0"

FLOOR B -16'-0"





PARAPET 88'-0"

ROOF 80'-0"

FLOOR 04 56'-0"

FLOOR 03 32'-0"

FLOOR 02 16'-0"

FLOOR 01 0'-0"

FLOOR B -16'-0"



## ZAHNER ENGINEERED PROFILE PANEL SYSTEM

“ZEPPS is a prefab building system to streamline complex structural forms. Zahner provides the system as a comprehensive solution, inclusive of the design-engineering, manufacturing and installation.” (Zahner)

“When used in architecture, ZEPPS forms can be developed to contain a complete wall system. This can include the exterior skin, waterproofing membrane, vapor barrier, structure, MEP, insulation, and interior wall substrate.” (Zahner)

The Zahner Drop & Lock system in Solanum Steel was initially selected as a symbol of the deterioration often associated with classic haunted houses and abandonment seen in horror movies. Opting for Zahner products, the ZEPPS system stood out as the optimal solution for the curvilinear structure. This innovative system was born out of collaboration with Frank Gehry during the design and development of the Experience Music Project in Seattle, Washington (Zahner). This building is now known as the Museum of Pop Culture, the host of the initial horror exhibit that influenced the Horrified project.

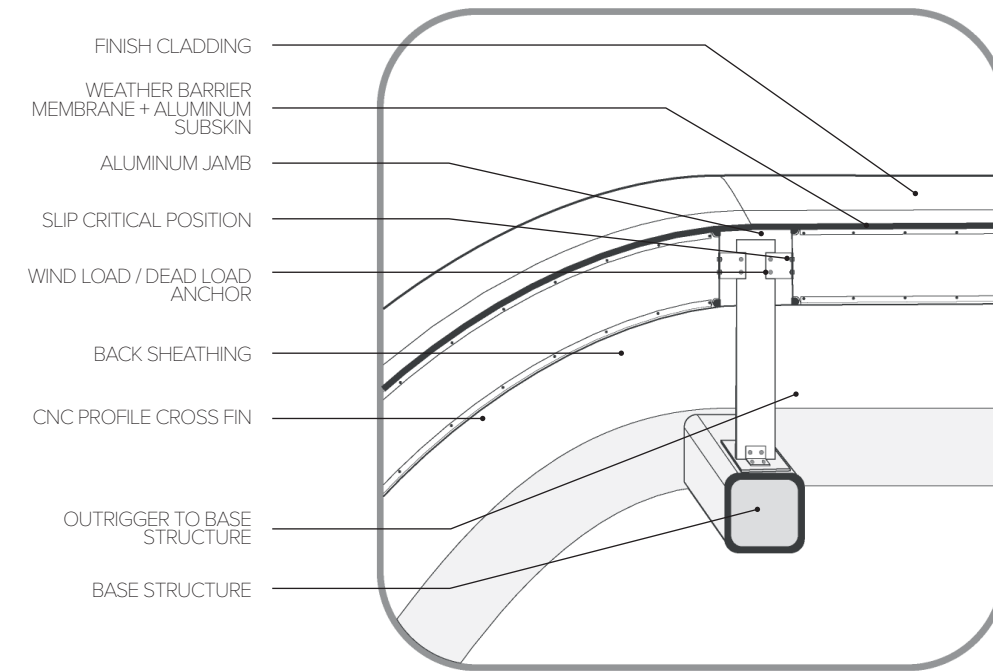
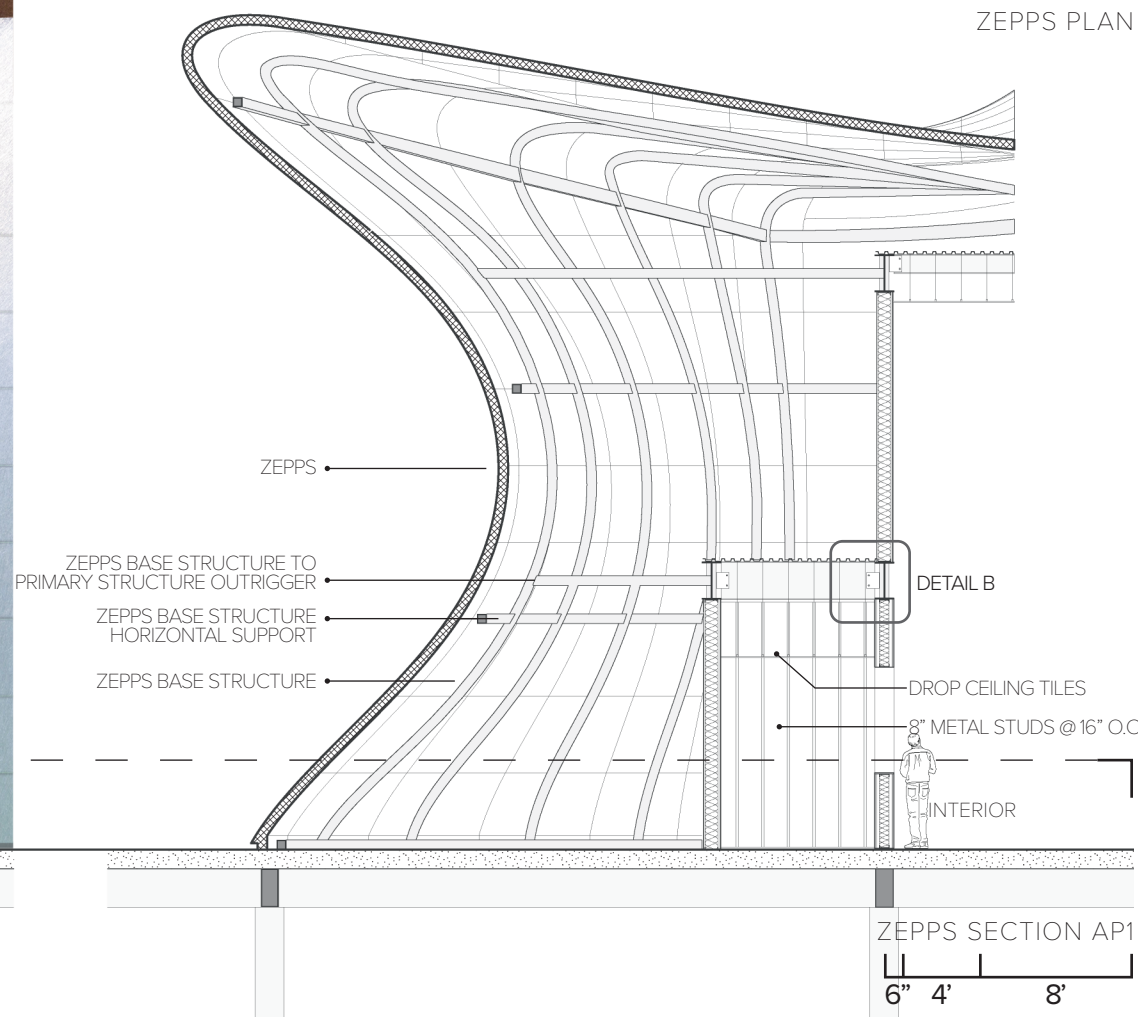
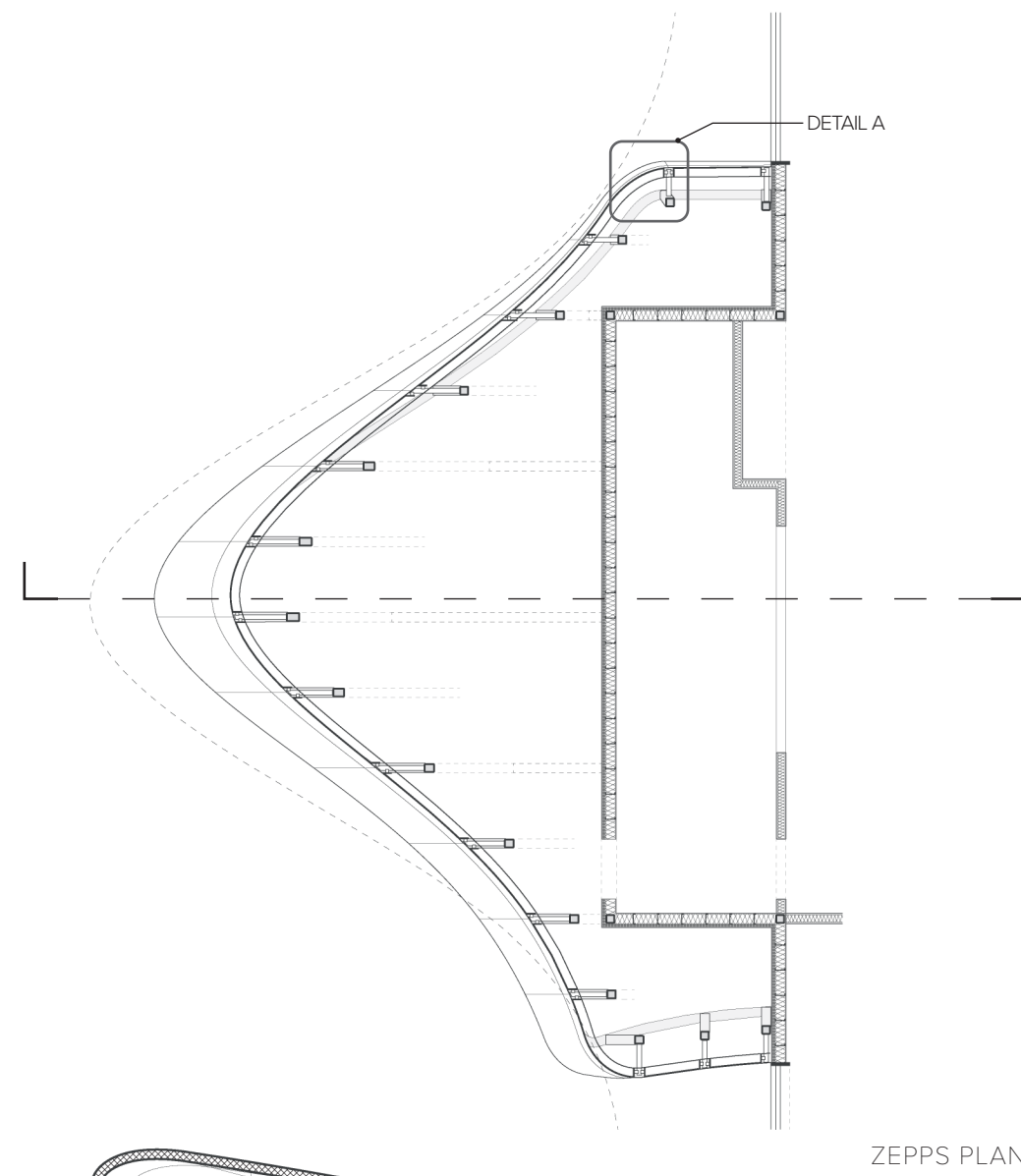
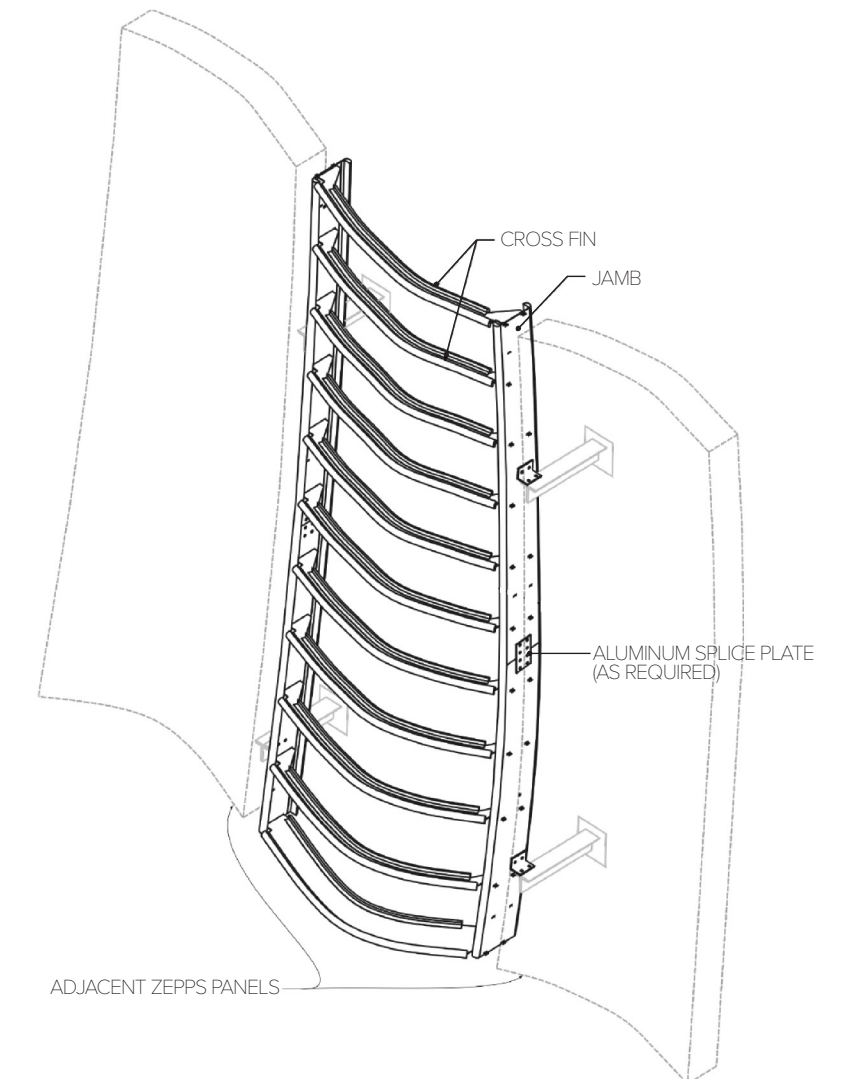

A) ZEPPS PANEL CONNECTION DETAIL

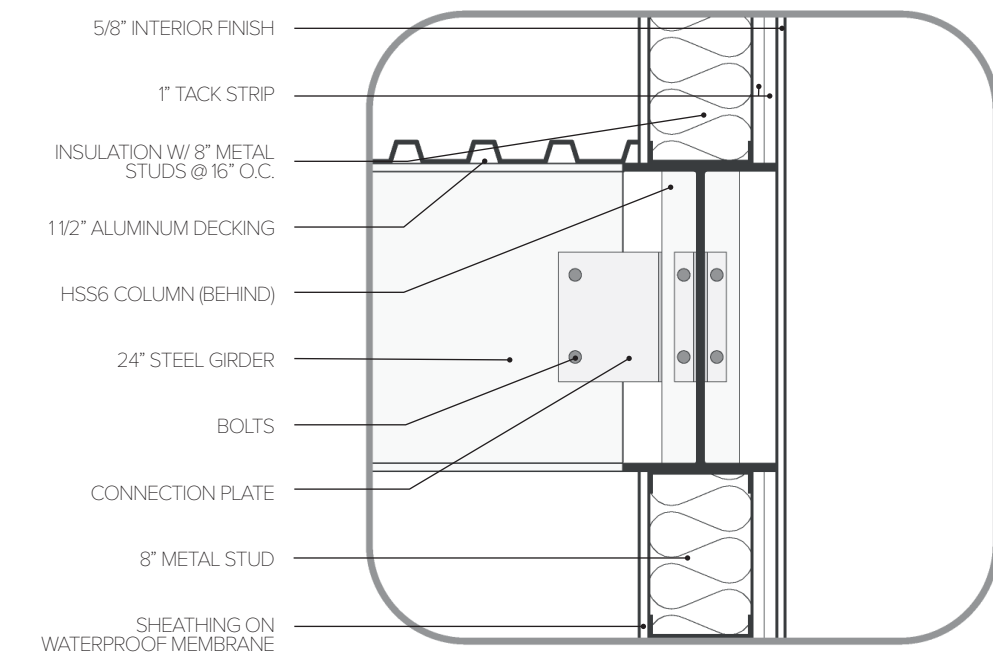

B) STRUCTURAL CONNECTION DETAIL

PARAPET 88'-0"

ROOF 80'-0"

FLOOR 4 56'-0"

LED SCREEN REPRESENTING ZAHNER DROP & LOCK SYSTEM IN SOLANUM STEEL

ZAHNER ENGINEERED PROFILE PANEL SYSTEM IN ANGEL HAIR STEEL

FLOOR 3 32'-0"

FLOOR 2 16'-0"

GROUND 0'-0"

ZEPPS S ELEVATION

ZEPPS SECTION A-P1

6" 4" 8"

4" 8" 12"



# THE TROJIAN HORSE





A prominent element that remained from the beginning of the design process and informed future design decisions was the 'street' connecting the North and South entries. Both of these entries are distinguished on the exterior by the use of the "blob" skin system.



PEREZ ART MUSEUM MIAMI  
MIAMI, FLORIDA / HERZOG & DE MEURON

The basement level of the Horror Movie Museum is dedicated to parking, offering 141 spaces for both employees and guests. It is limited in space due to its adjacency to the Perot parking, as well as a number of other lots and parking garages. The design ensures efficient flow, with cars entering from the West and exiting from the East side of the building. Inspired by the parking design at the Miami Perez Museum in Florida, three sets of stairs embellished with natural plants provide access to the primary Southern plaza. For those requiring elevator access, a dedicated elevator transports them to the plaza level.

This level serves as an employee-only entry point, with the door leading directly into the collections area. Here, all spaces related to collections management are located, excluding the workshop and curator's office. Additionally, a loading dock facilitates collections deliveries and supplies for the museum's stores, café, and theater. The dock doors open directly into a two-way freight elevator at the center of the service core, alongside a personal elevator for employees. Emergency exits for the museum's two movie theaters are also situated on this floor.

- 1 COLLECTION STORAGE
- 2 CRATE STORAGE
- 3 DELIVERY AND RECEIVING
- 4 OFFICE
- 5 COLLECTION PROCESSING AND HOLDING
- 6 EQUIPMENT STORAGE
- 7 JANITORIAL
- 8 RESTROOMS
- 9 GENERAL STORAGE

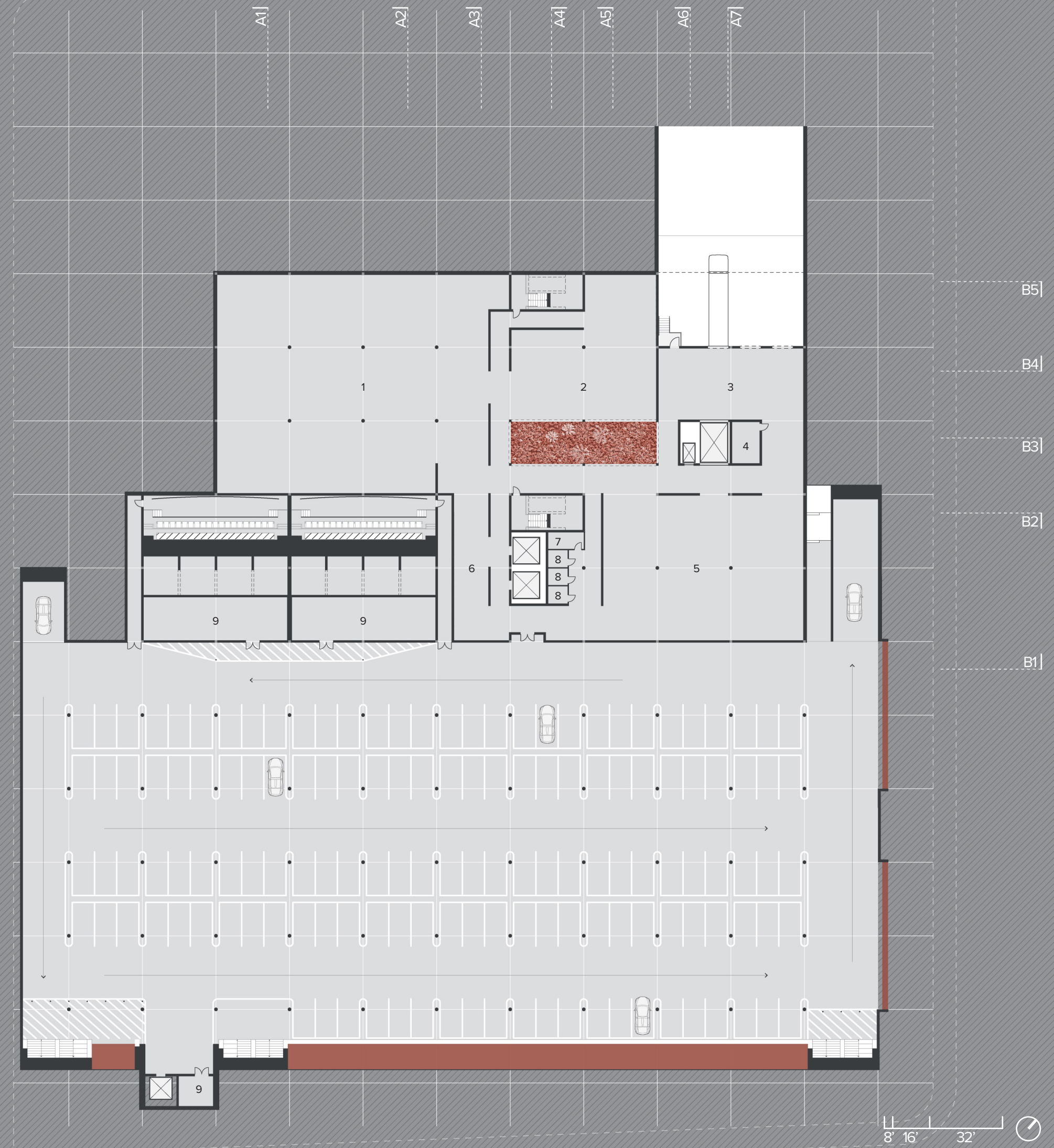



The building takes the form of a substantial prism measuring 192 feet by 256 feet, excluding the portion enveloped by the skin, with limited windows resulting in minimal access to natural daylight. Recognizing the importance of natural light for both administrative staff and museum floor workers, ensuring its availability was a primary consideration during the initial schematic development.

To address this need, a lightwell positioned near the building's core was proposed as a solution. Beyond providing natural light, this lightwell serves a multifunctional purpose. Curators have the opportunity to integrate museum content within the lightwell, creating a centralized, multi-level gallery accessible from all floors. This innovative approach allows visitors to view the content from both above and below, offering a unique perspective not commonly associated with traditional three-dimensional artwork.



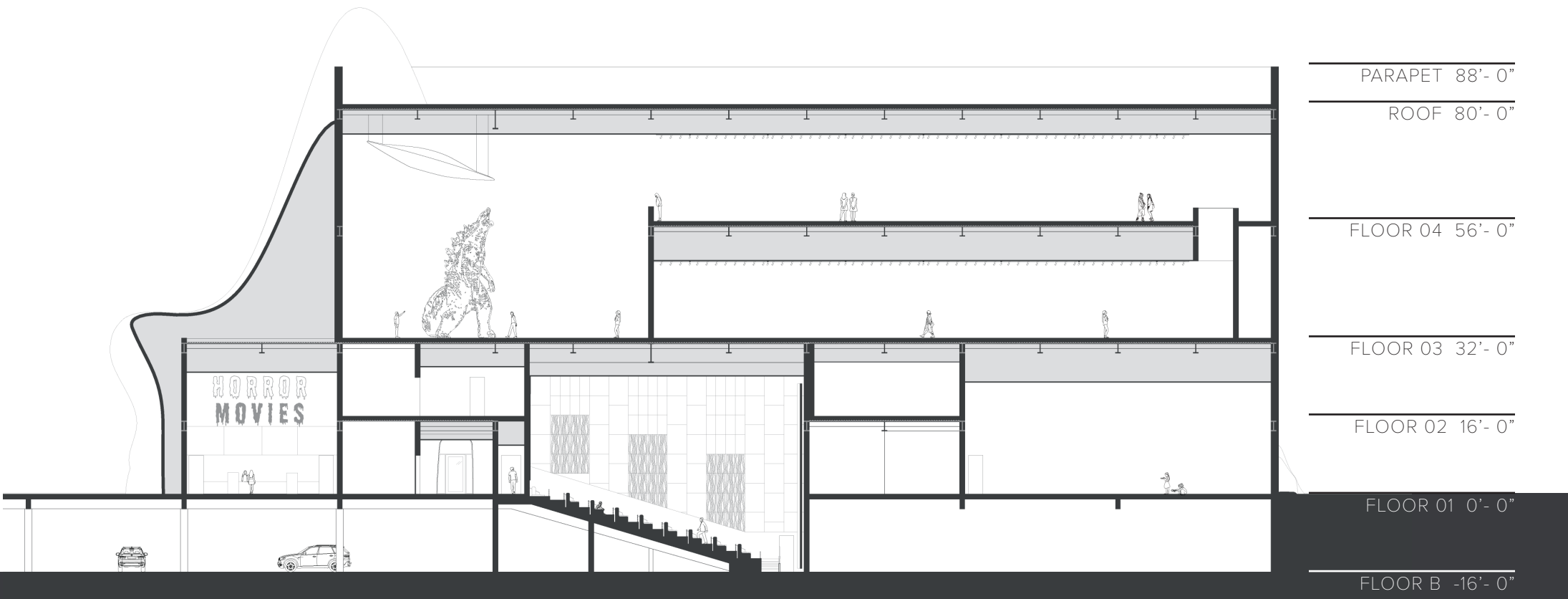

BUILDING SECTION A1

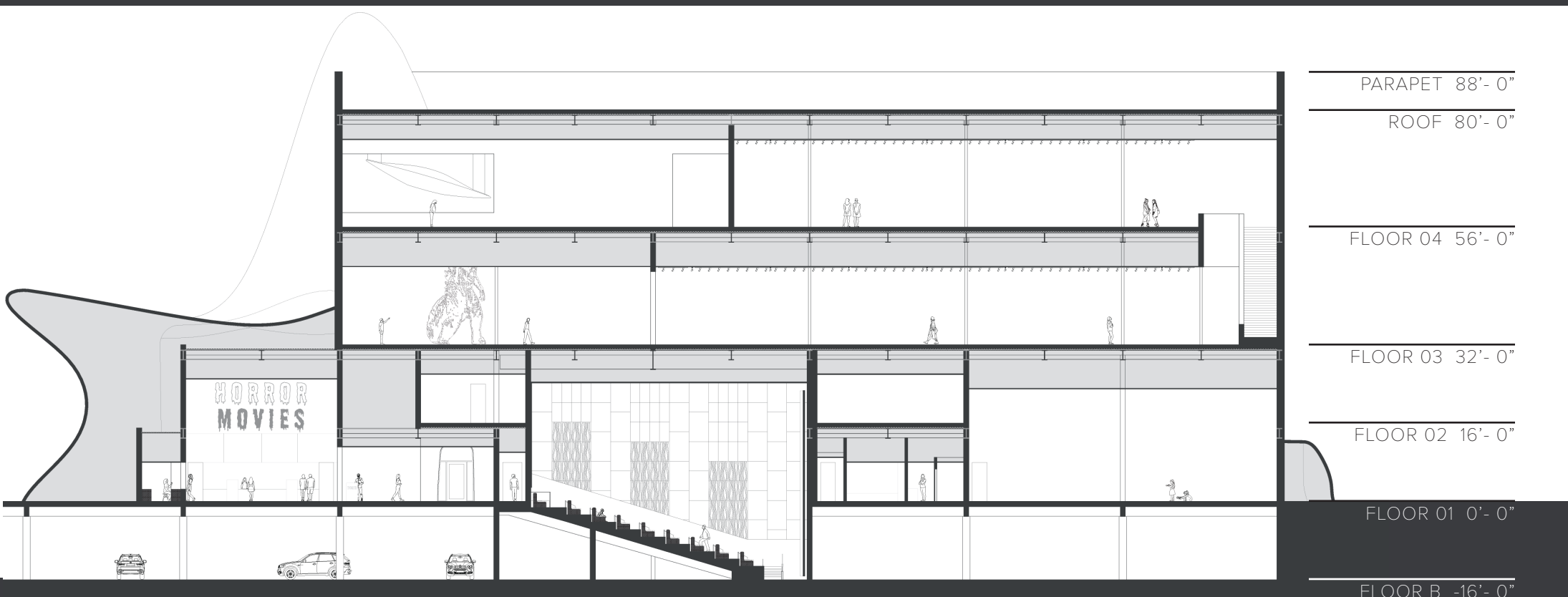

BUILDING SECTION A2

The concept of incorporating a theater was first introduced during the architectural programming class's discussion on the matrix. The decision aimed to enrich and diversify the building's utility. Beyond hosting late-night horror screenings, the theater serves as a venue for premieres and special events. Its spacious lobby is purposely designed to accommodate various occasions, while a private special event space on the fourth floor caters to exclusive gatherings.

By day, visitors are drawn to explore the curious collections and experience a thrill. However, by night, the theater becomes a hub for classic horror cinema, limited releases, silent films, and an array of offerings within the genre, enticing enthusiasts to immerse themselves in the cinematic experience.

The materials within the theater consist of Armstrong Acoustibuilt Seamless Acoustical Wall and Ceiling Systems, as well as Armstrong DesignArt high NRC Walls. The Acoustibuilt has the "look of drywall in a seamless acoustical ceiling and wall system" (Armstrong) and the DesignArt panels "transform interior spaces with a three-dimensional visual by combining texture, routed patterns and colors with acoustical, sustainable TECTUM DESIGNART" (Armstrong).

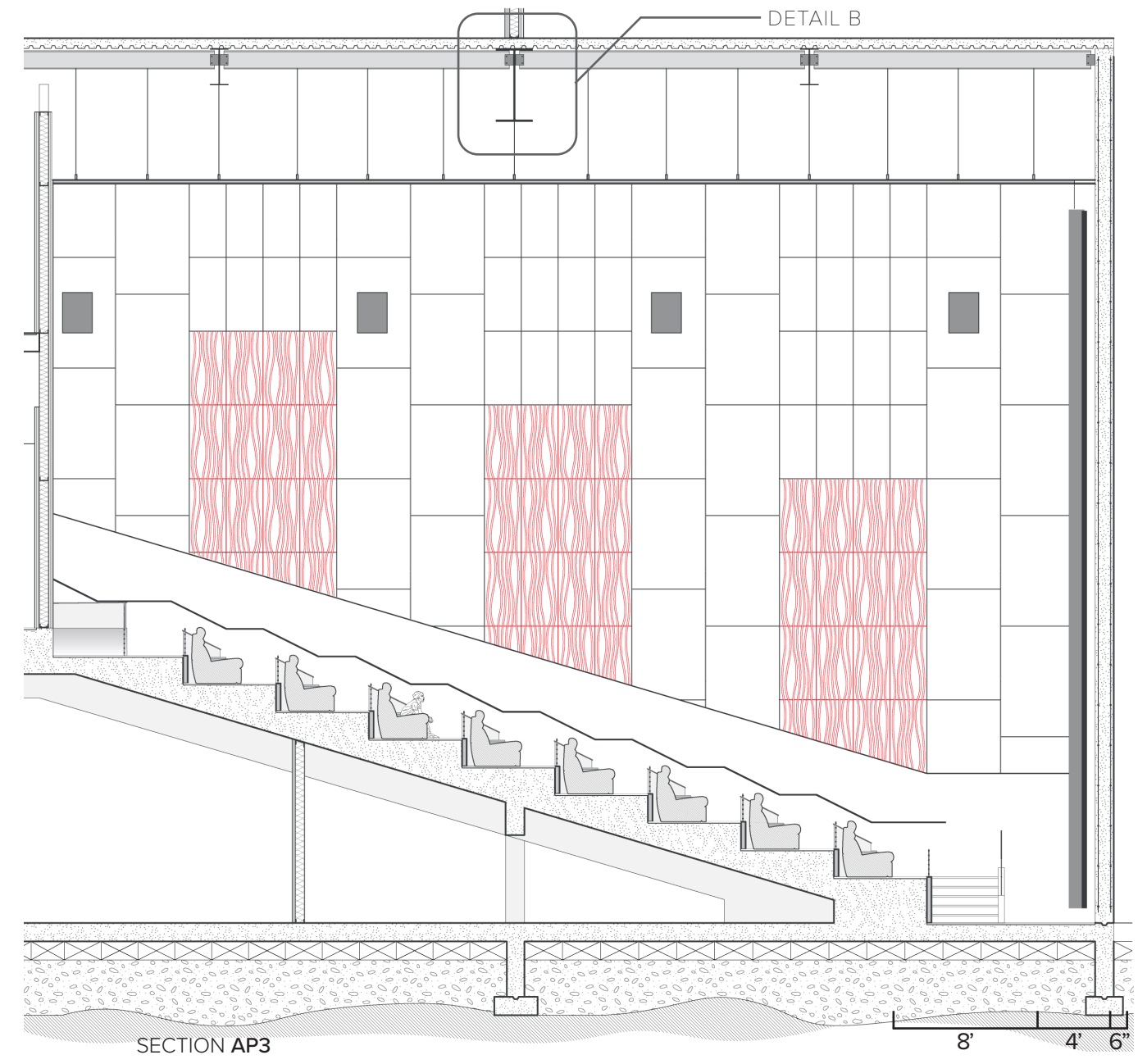

SECTION AP3

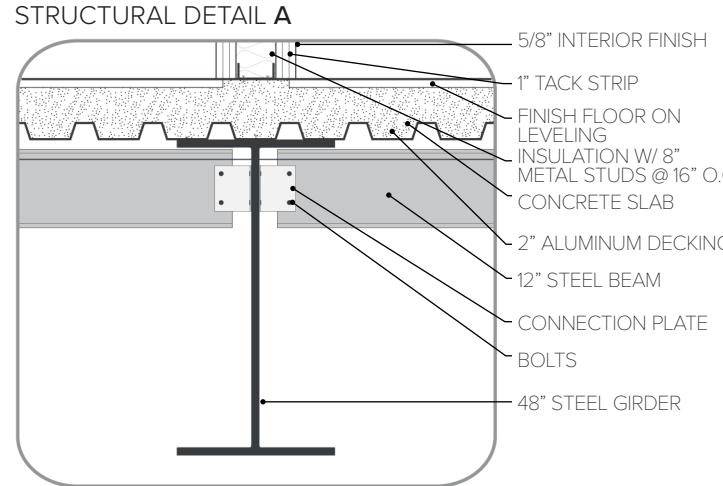
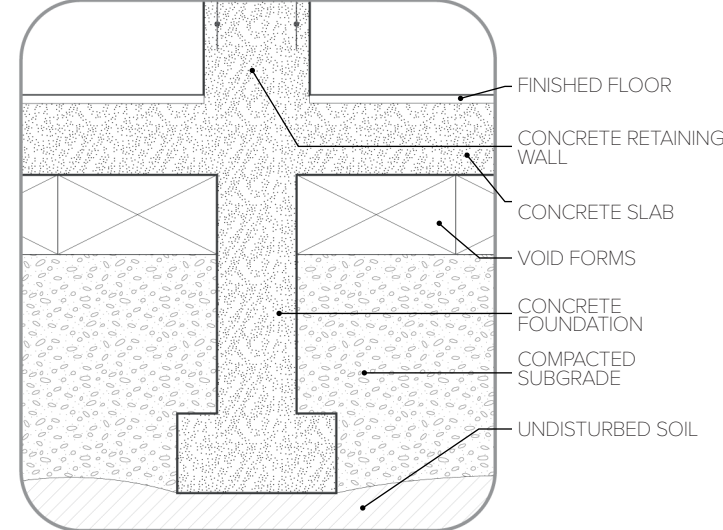
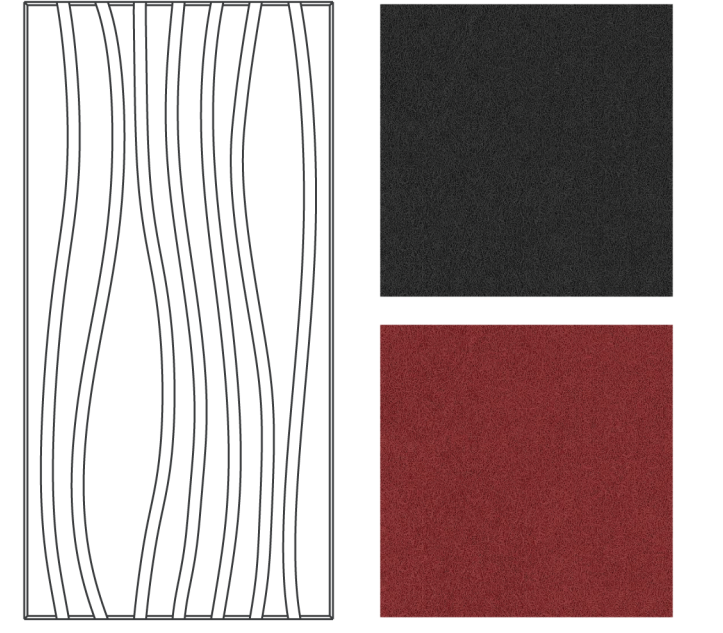
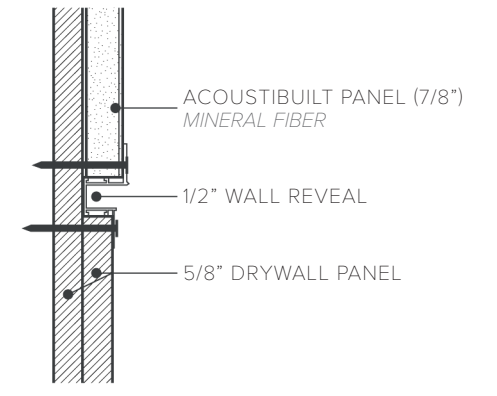

STRUCTURAL DETAIL B



RENDER THEATER

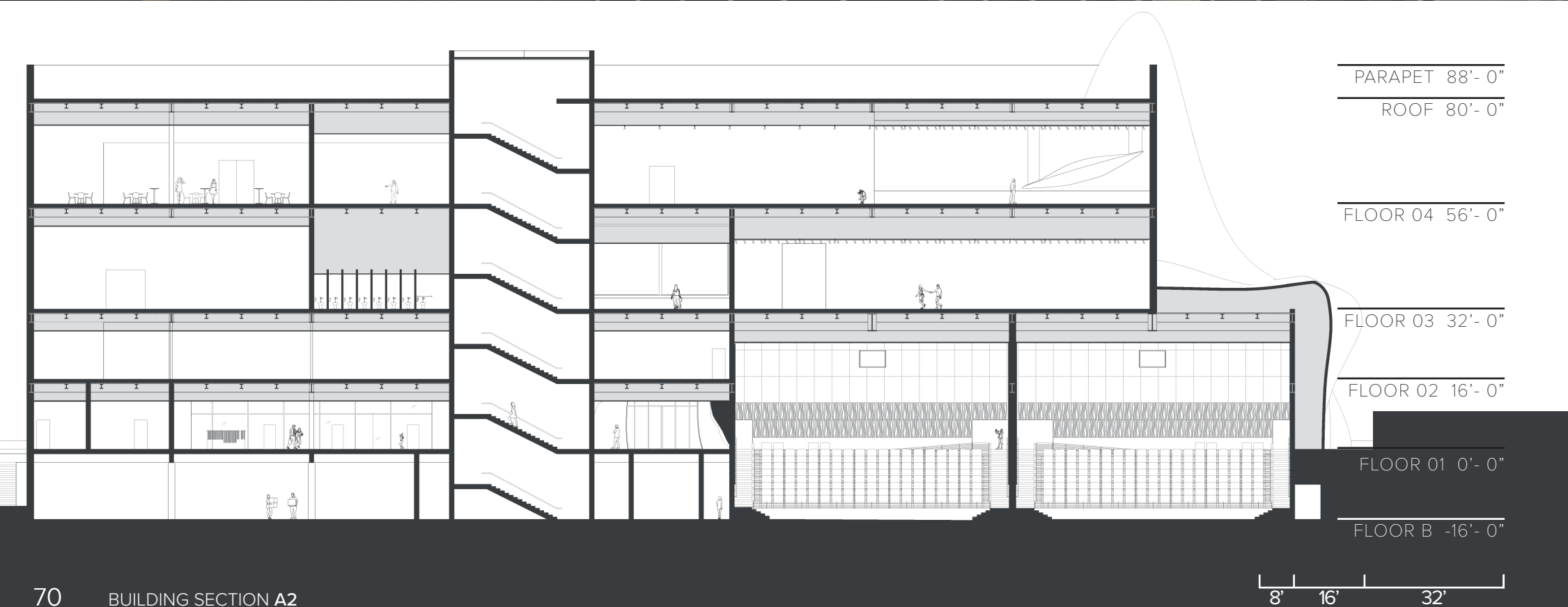

The first floor encompasses various spaces, including the entrances to the North and South lobbies and the movie theater. The theater lobby features its own independent entrance, facilitating separate operation from the museum. Inside, guests find concession stands, seating areas, and a ticket booth cleverly integrated into the structure of the skin. With two theaters, each seating 160 people, the theater shares an entrance with the museum for easy access during open hours.

The Southern lobby offers a range of activities, from photobooths to character encounters. A themed café and museum shop are accessible without requiring a ticket. The spiral staircase descends from the third floor but serves as an exit only on the first floor. Guests seeking access to the museum exhibits must pass through ticket check, label for on page 73, before taking the elevators to the fourth floor. While starting from the fourth floor is not mandatory, it is recommended for visitors intending to explore all exhibits.

On the North side, VIP and guest entry, as well as access for those using handicap accessible parking, are located. Tickets are checked upon entry. Notably, the Northern lobby features the presence of the blob, symbolizing its infiltration into the building.

A children's exhibit is accessible from the North lobby, providing interactive experiences such as an AI-powered horror story area and insights into filmmaking. Inspiration is drawn from the traveling Pixar exhibit, which visited the Perot Museum in the summer of 2023. Displays on "children's horror," including Coraline, Goosebumps, and Hotel Transylvania, are featured.

Educational classrooms and the collections workshop, housing curator and collection manager offices, are situated on the first floor. With two stories allowing ample natural light, the workshop serves as a space for collection work and interactive class activities.

- |                  |                        |
|------------------|------------------------|
| 1 THEATER LOBBY  | 13 PRIMARY ENTRY       |
| 2 TICKET SALES   | 14 MUSEUM LOBBY        |
| 3 CONCESSIONS    | 15 CAFE                |
| 4 TICKET CHECK   | 16 MUSEUM STORE        |
| 5 EMPLOYEE AREA  | 17 FACILITY EQUIPMENT  |
| 6 THEATER OFFICE | 18 CHILDREN'S EXHIBIT  |
| 7 KITCHEN        | 19 GROUP / VIP ENTRY   |
| 8 STORAGE        | 20 RESOURCE AREA       |
| 9 JANITORIAL     | 21 LIGHT WELL          |
| 10 RESTROOM      | 22 EDUCATIONAL ROOMS   |
| 11 THEATER 1     | 23 COLLECTION WORKSHOP |
| 12 THEATER 2     | 24 OFFICES             |

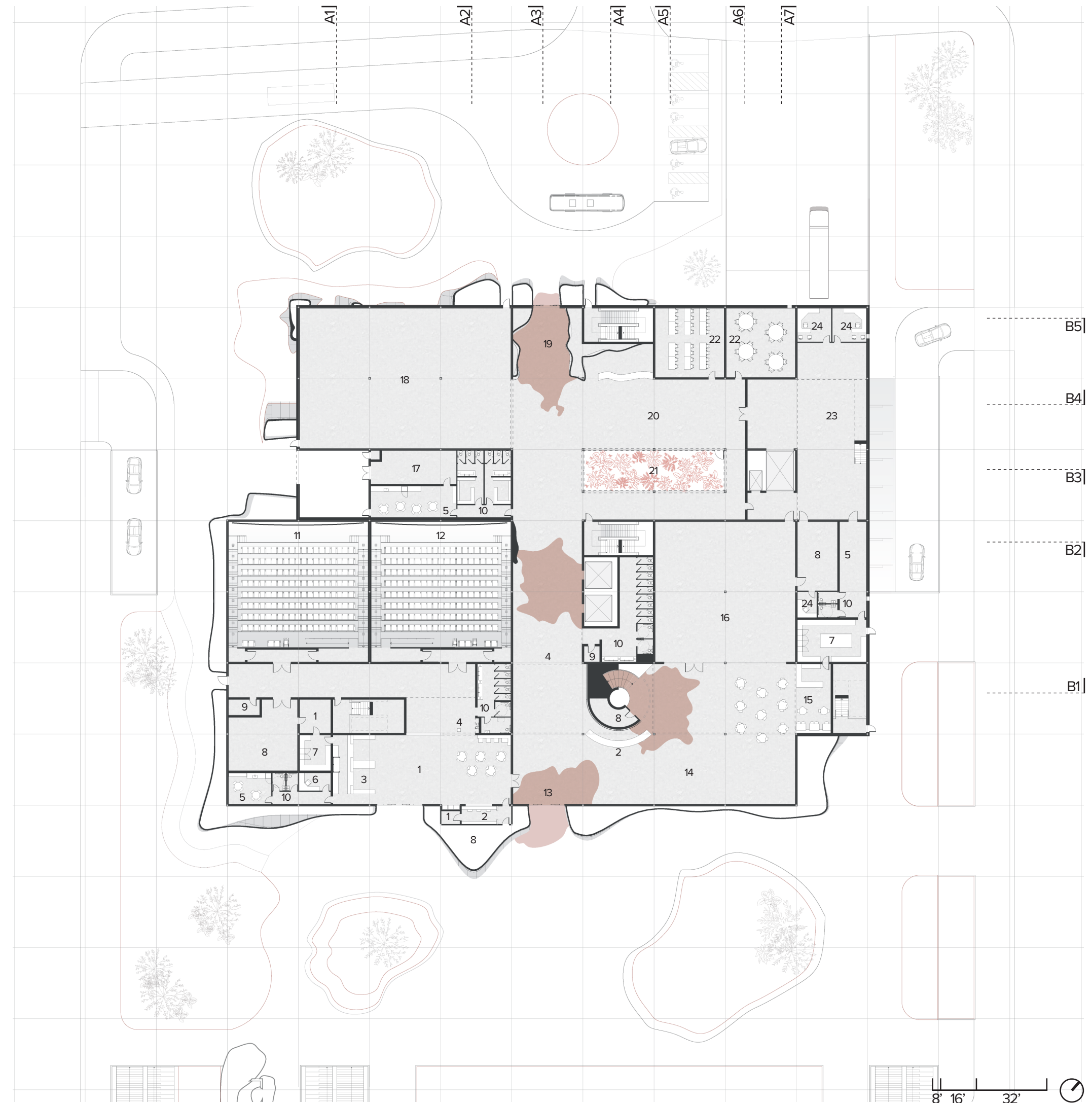

Guests entering through the Northern entrance are immediately immersed in an experience of expansion and contraction. Despite its relatively smaller height, this entrance features more dramatic elements, including the sensation of a blob seemingly entering alongside the guest through the doorway. Additionally, the lightwell that traverses the building is visible from this side, adding to the dynamic atmosphere of the entrance.

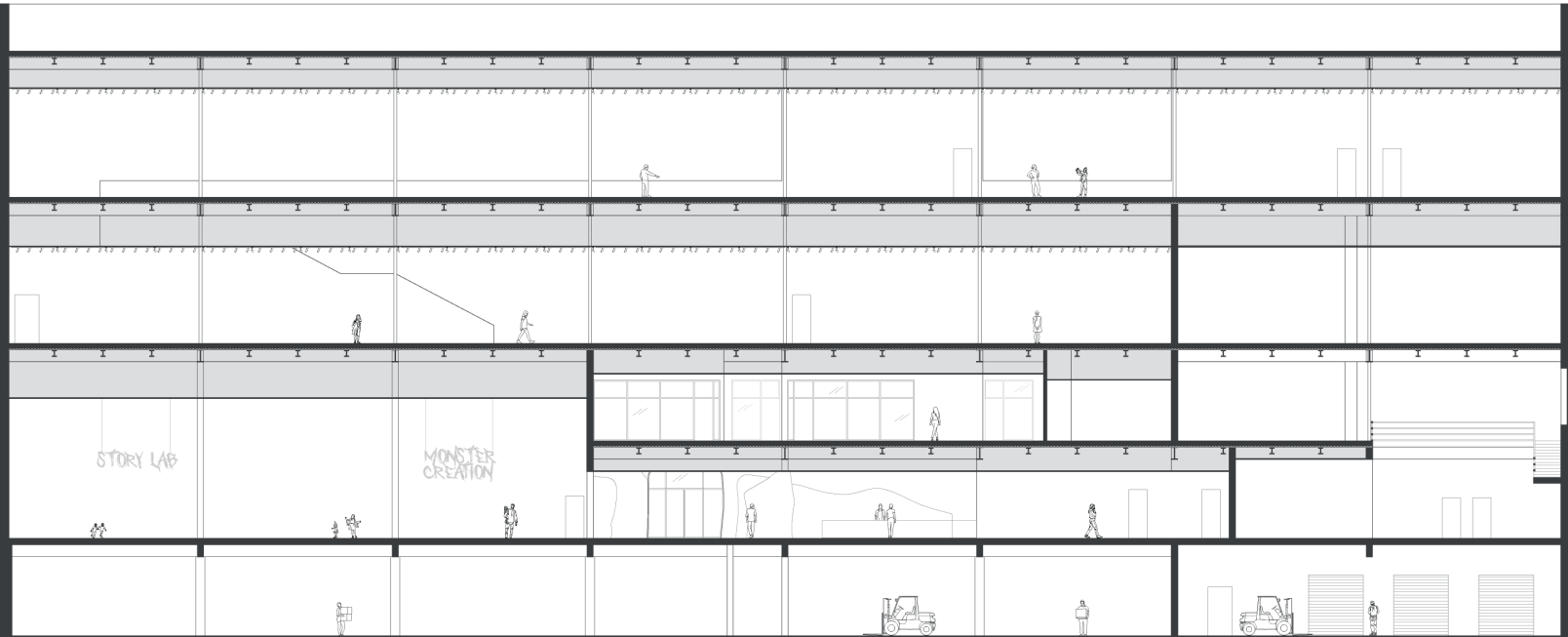

- PARAPET 88'- 0"
- ROOF 80'- 0"
- FLOOR 04 56'- 0"
- FLOOR 03 32'- 0"
- FLOOR 02 16'- 0"
- FLOOR 01 0'- 0"
- FLOOR B -16'- 0"



RENDER NORTH LOBBY

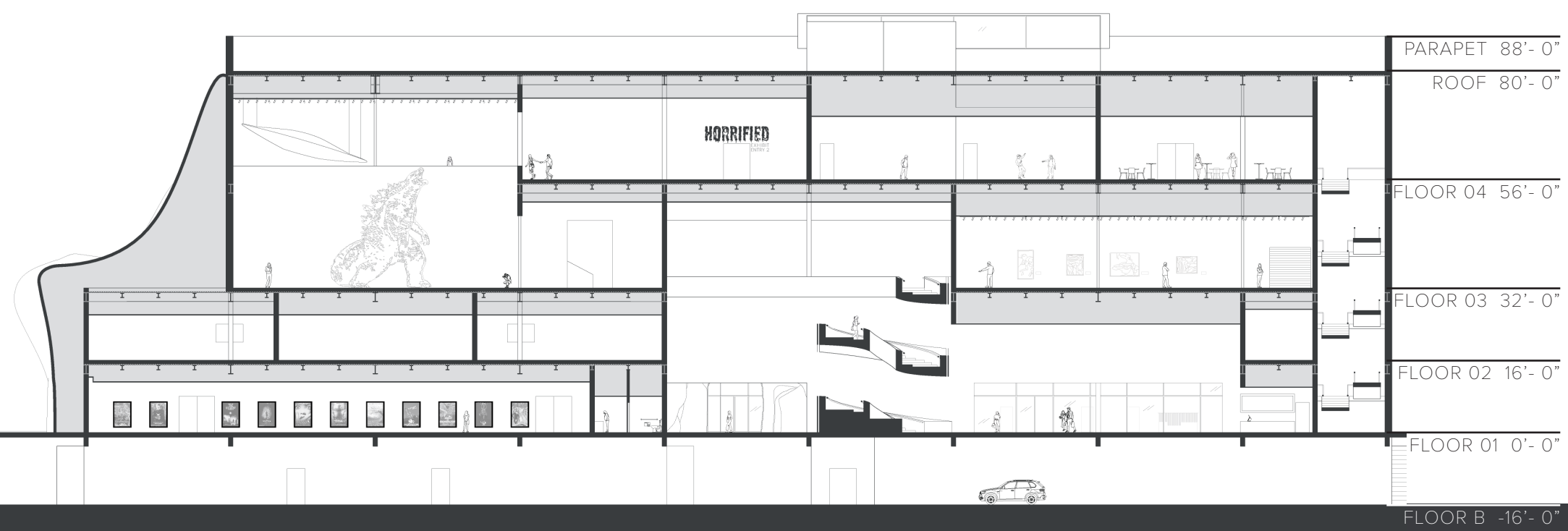
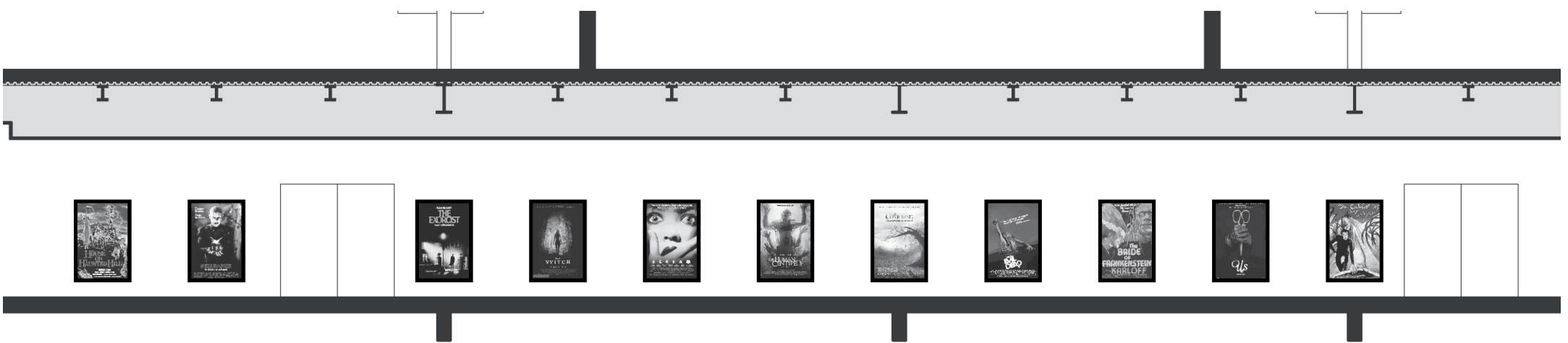



The second floor is off-limits to the general public and serves primarily administrative and operational functions. Within the theater area, two projection rooms double as storage spaces. Upon exiting the elevator, visitors are greeted by the administration's reception and waiting area to the right, while the security office is located to the left.

The administration office features a bullpen area, two conference rooms, a breakroom, a copy and work room, and offices of varying sizes. Additionally, the second floor houses part of the collection's workshop. A notable feature of this floor is a large window that allows ample natural light to filter in. Although not visible from the exterior elevation, the window is covered with perforated metal panels, designed to retain aesthetic consistency while still permitting natural light.

Furthermore, the second floor accommodates a sizable communications and electrical room to support the museum's extensive technological infrastructure and growth, along with a mechanical room for equipment maintenance and operation.

- |                              |                    |
|------------------------------|--------------------|
| 1 RECEPTION                  | 8 COLLECTIONS      |
| 2 BULLPEN                    | MEZZANINE          |
| 3 OFFICE                     | 9 JANITORIAL       |
| 4 CONFERENCE ROOM            | 10 STORAGE         |
| 5 BREAK ROOM                 | 11 RESTROOM        |
| 6 WORK ROOM                  | 12 MECHANICAL      |
| 7 ELECTRICAL / COMMUNICATION | 13 SECURITY OFFICE |
|                              | 14 PROJECTION ROOM |

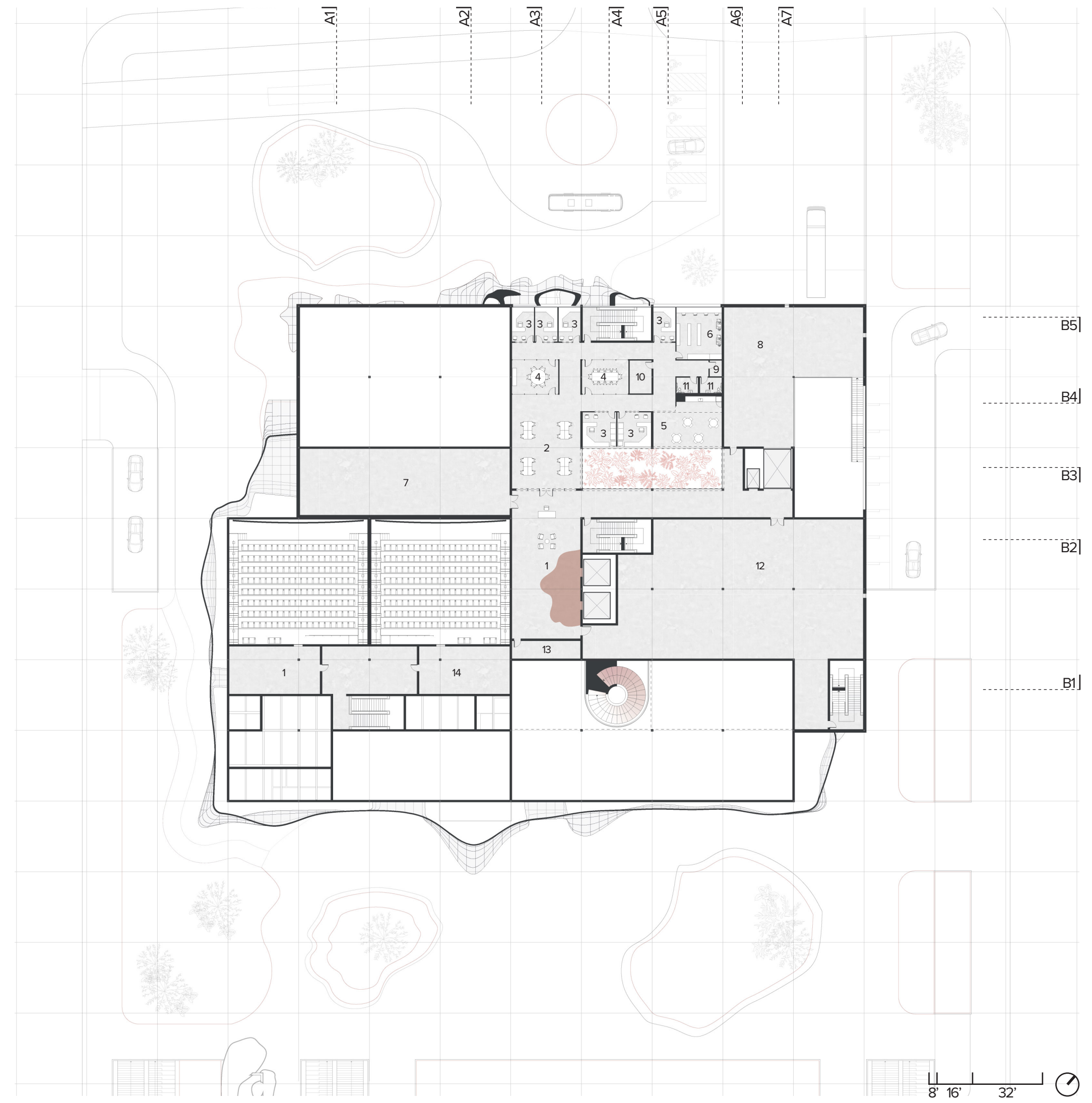

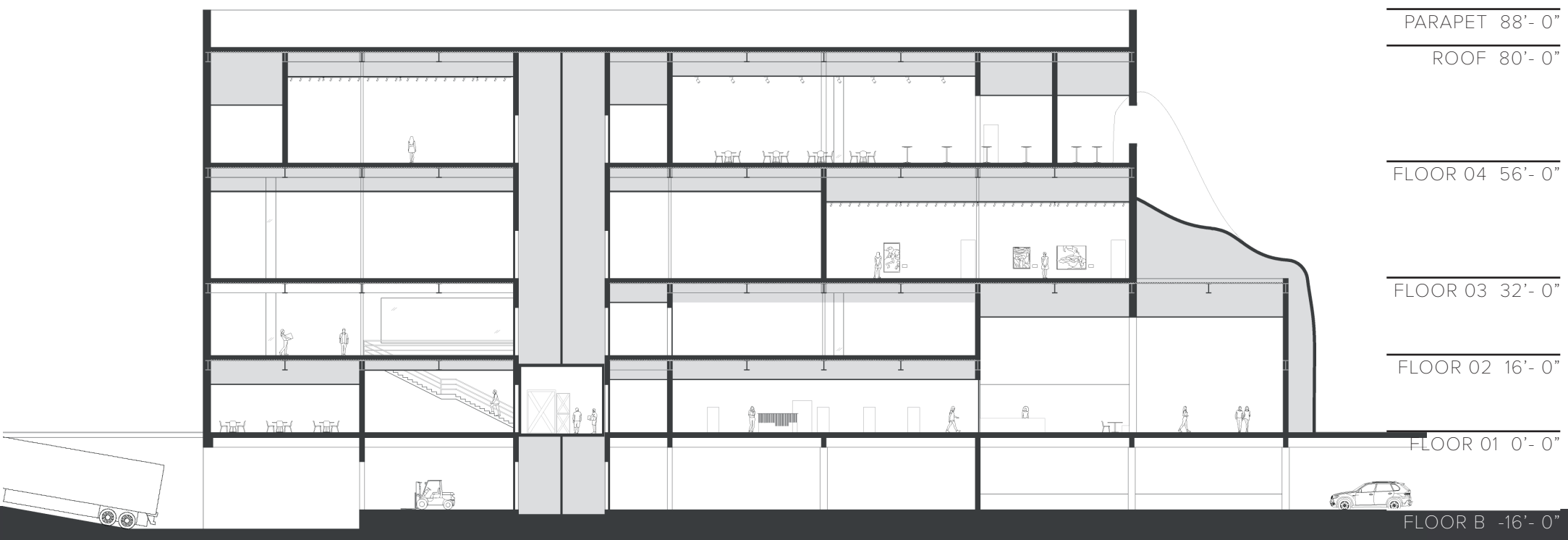

PARAPET 88'-0"  
 ROOF 80'-0"  
 FLOOR 04 56'-0"  
 FLOOR 03 32'-0"  
 FLOOR 02 16'-0"  
 FLOOR 01 0'-0"  
 FLOOR B -16'-0"



RENDER ADMINISTRATION

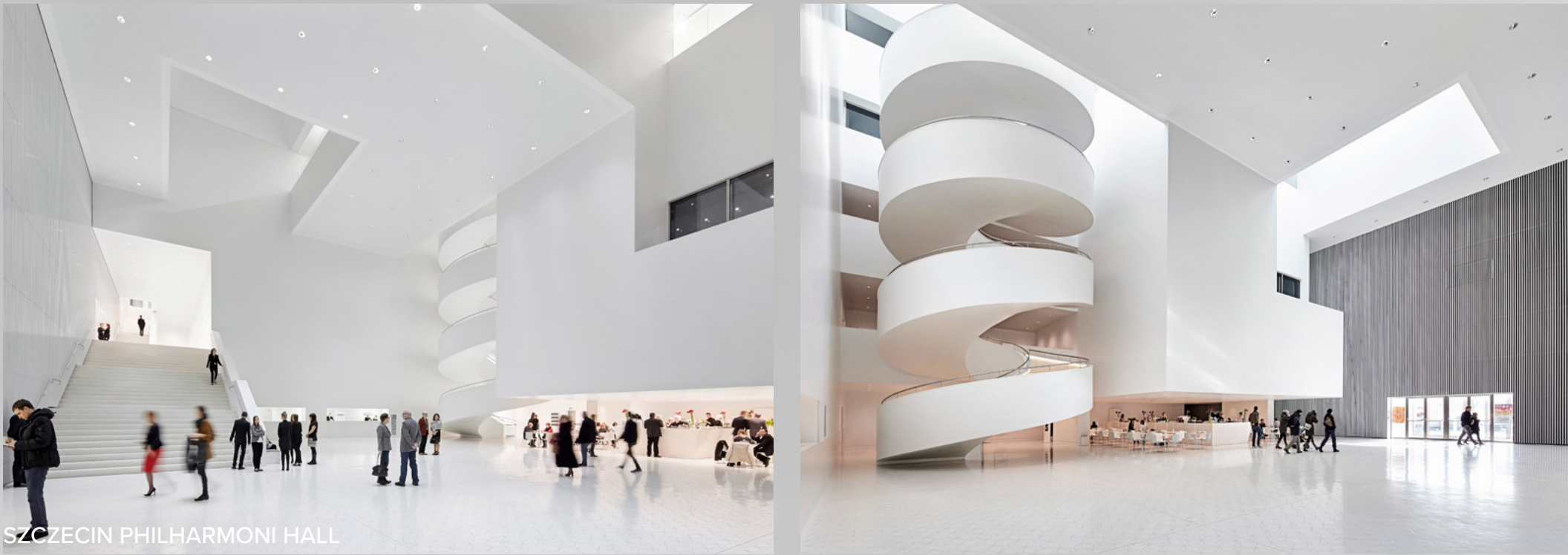

SZCZECIN PHILHARMONI HALL  
POLAND / BAROZZI VEIGA

The third floor encompasses the temporary exhibit, rotating exhibits, and the expansive large-scale exhibit. The large-scale exhibit, number 6 on page 83, is dedicated to large-scale pieces such as Godzilla or UFOs and offers guests the opportunity to view these displays up close.

Following the museum's recommended top-down exploration approach, the third floor serves as the final destination before guests return to the lobby to browse souvenirs. While guests have the option to use the elevators if needed, they are strongly encouraged to exit via the spiral staircase. This staircase not only facilitates circulation but also offers a memorable experience in itself. Positioned to open into the lobby, the staircase provides a breathtaking view of Downtown Dallas from its landing on the third floor. Inspired by the design of Barozzi Veiga in the Szczecin Philharmonic Hall, this staircase transcends mere functionality, becoming an integral part of the museum experience.

- 1 TEMPORARY EXHIBIT
- 2 VIDEO ROOM
- 3 SHOP
- 4 SHOP STORAGE
- 5 EXIT TO LOBBY
- 6 LARGE SCALE LOWER LEVEL
- 7 ROTATING EXHIBITS
- 8 STAGING AREA
- 9 RESTROOMS
- 10 STORAGE
- 11 LIGHT WELL

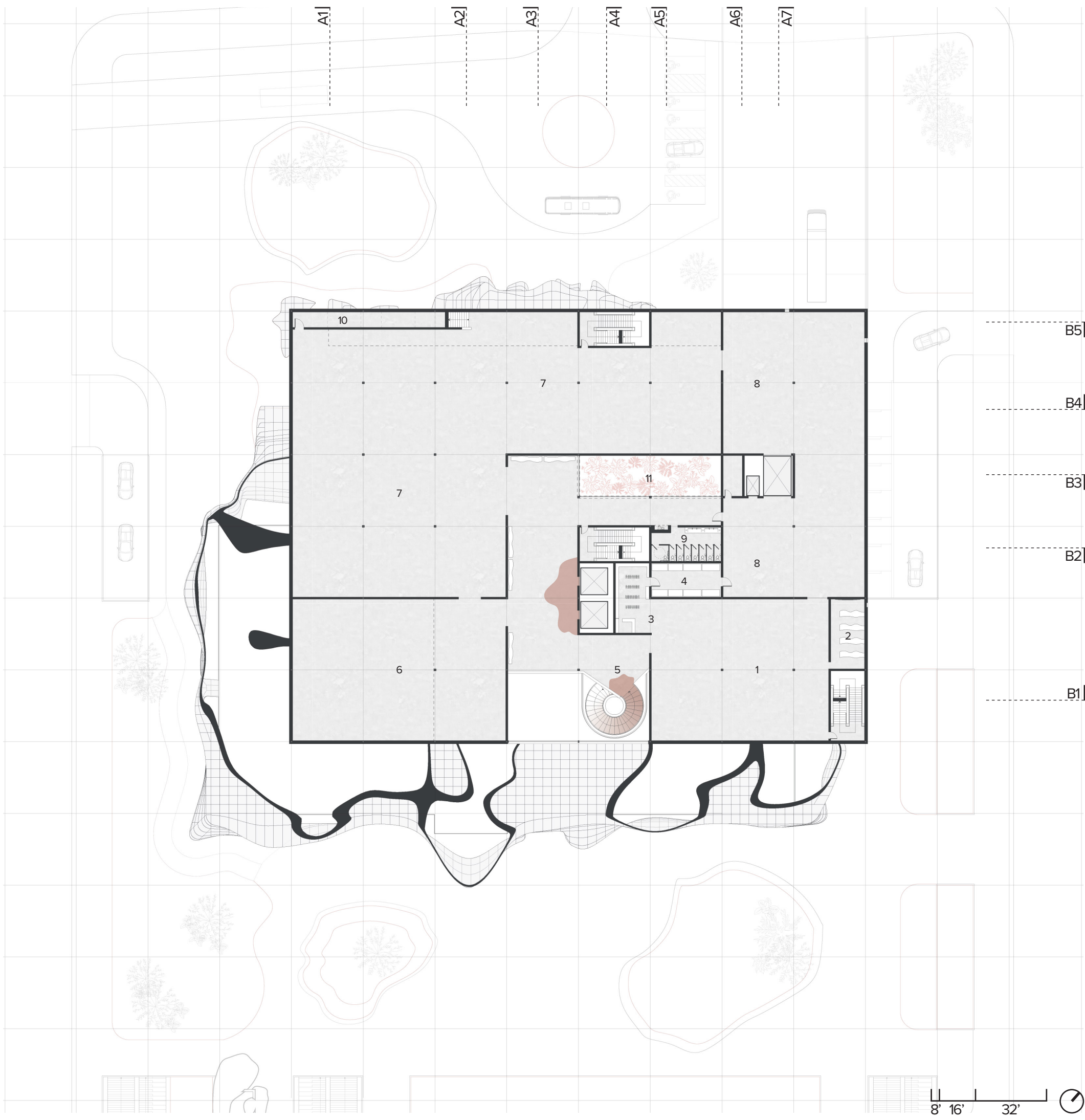

The temporary exhibits encompass a gallery space, a small store, and a video room, providing a dynamic environment for showcasing diverse content. Exhibitions in this space rotate approximately every 4-6 weeks, enticing repeat visitors to return frequently to experience new works. While the scale of content in this gallery may be smaller compared to other exhibit spaces, it offers an opportunity for the exploration of horror beyond cinema.

For instance, fine art pieces that explore themes akin to those found in horror movies, as depicted on page 85, can find a home here. The space is versatile, capable of hosting lectures directly within the exhibit area or in adjacent first-floor classrooms, further delving into the concept of horror across different mediums.

Moreover, the temporary exhibit space is ideal for showcasing the works of directors such as Jordan Peele or Alfred Hitchcock, as well as exploring sub-genres, historical periods, and the evolution of horror within a rapidly changing society.

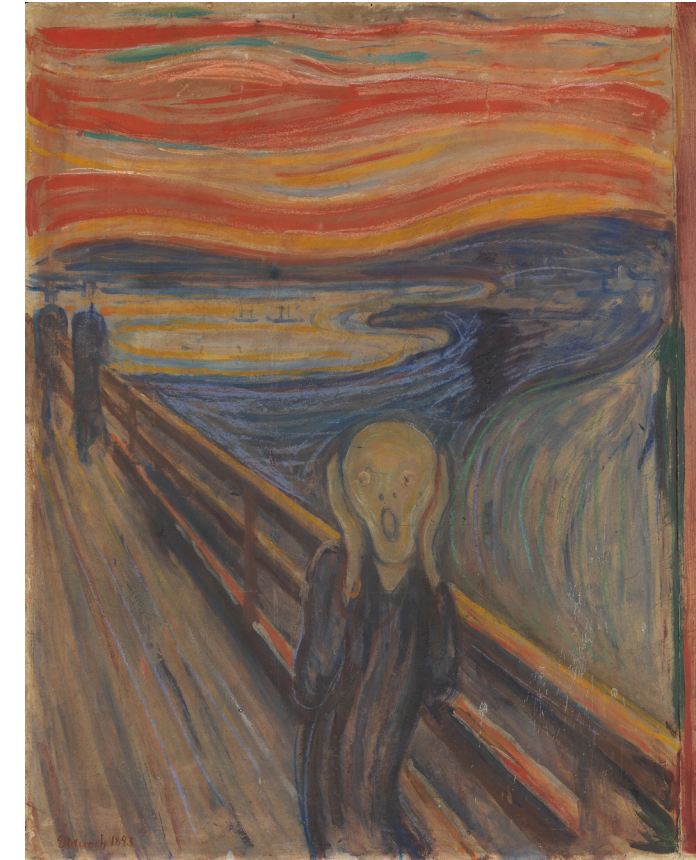
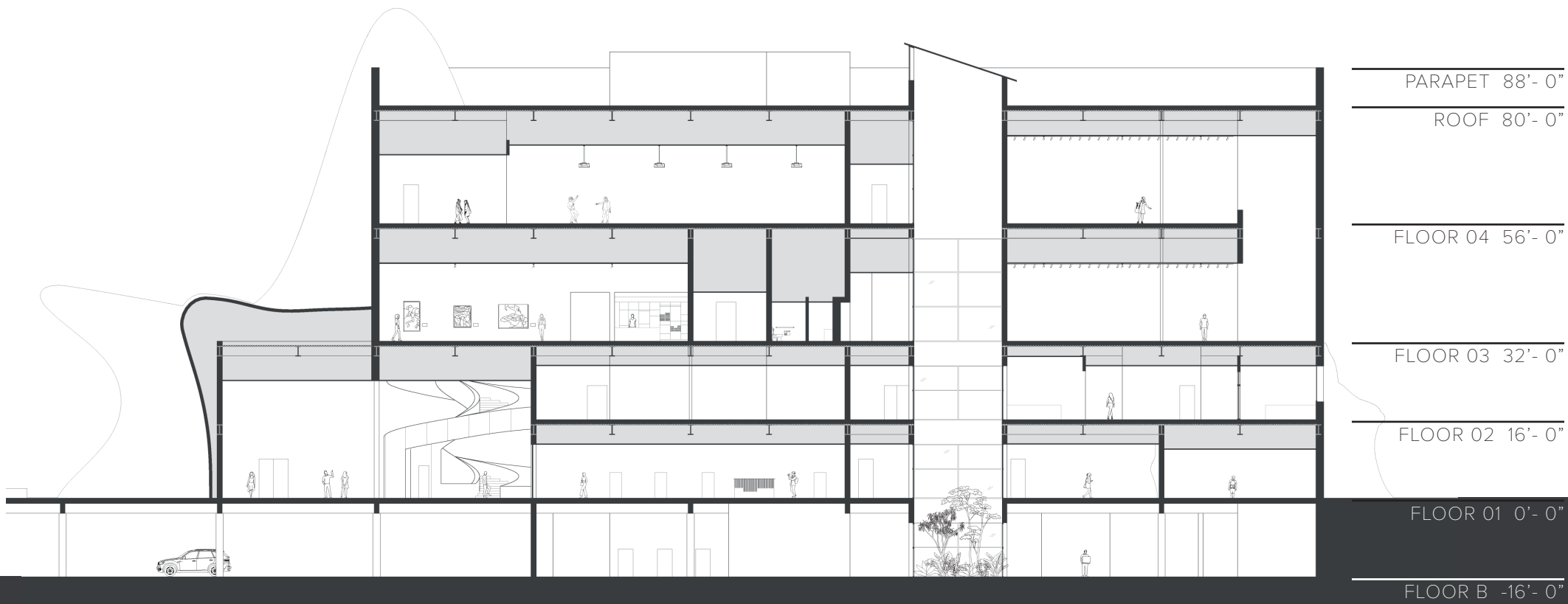

*The Scream* // Edvard Munch  
 1893

Symbol of anxiety of the human existence

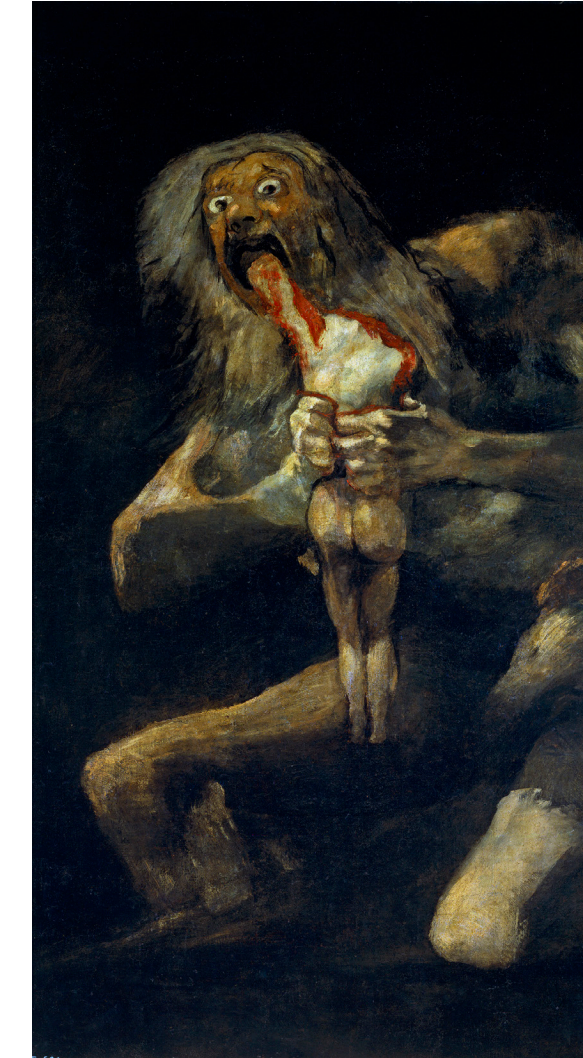

*Saturn Devouring His Son* // Francisco Goya  
 1819 - 1823

Father eating his own children



*The Nightmare* // Henry Fuseli  
 1781

Innate fears of the subconscious and vulnerability of sleep



The rotating exhibit spaces are strategically designed to accommodate between four and six interconnected exhibits, each lasting 3-4 months. Unlike the permanent exhibits, these spaces will feature diverse contributions from various individuals within the genre, offering a multifaceted exploration of horror. Additionally, the gallery may showcase horror films representing different typologies discussed in *Horror in Architecture*, expanding the scope of content available for visitors.

Illustrated on page 87 is a long staircase leading from the fourth floor. Similar to the spiral stair, this serves as a one-way exit from the fourth-floor exhibit to the third floor, providing an optimal route for guests navigating through the museum. However, it's important to note that while this route is recommended, it's not the sole way to experience the museum's offerings.

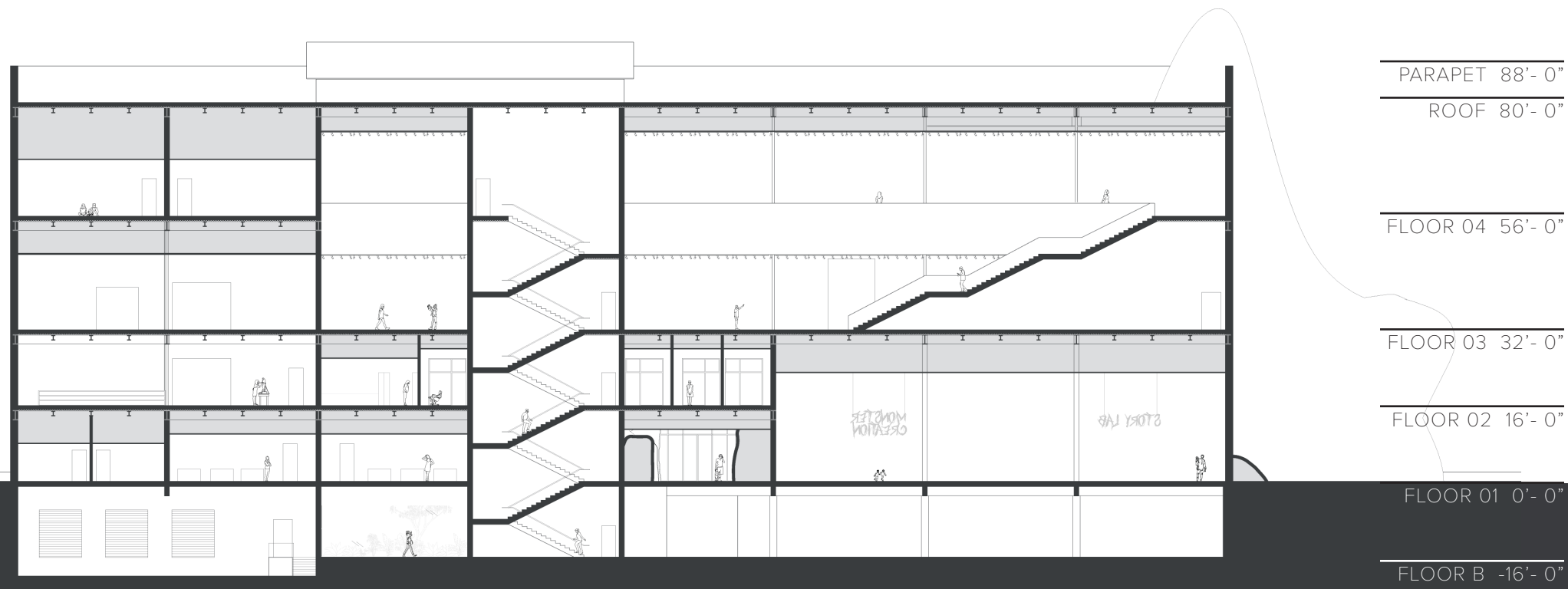

RENDER THIRD FLOOR STAIR





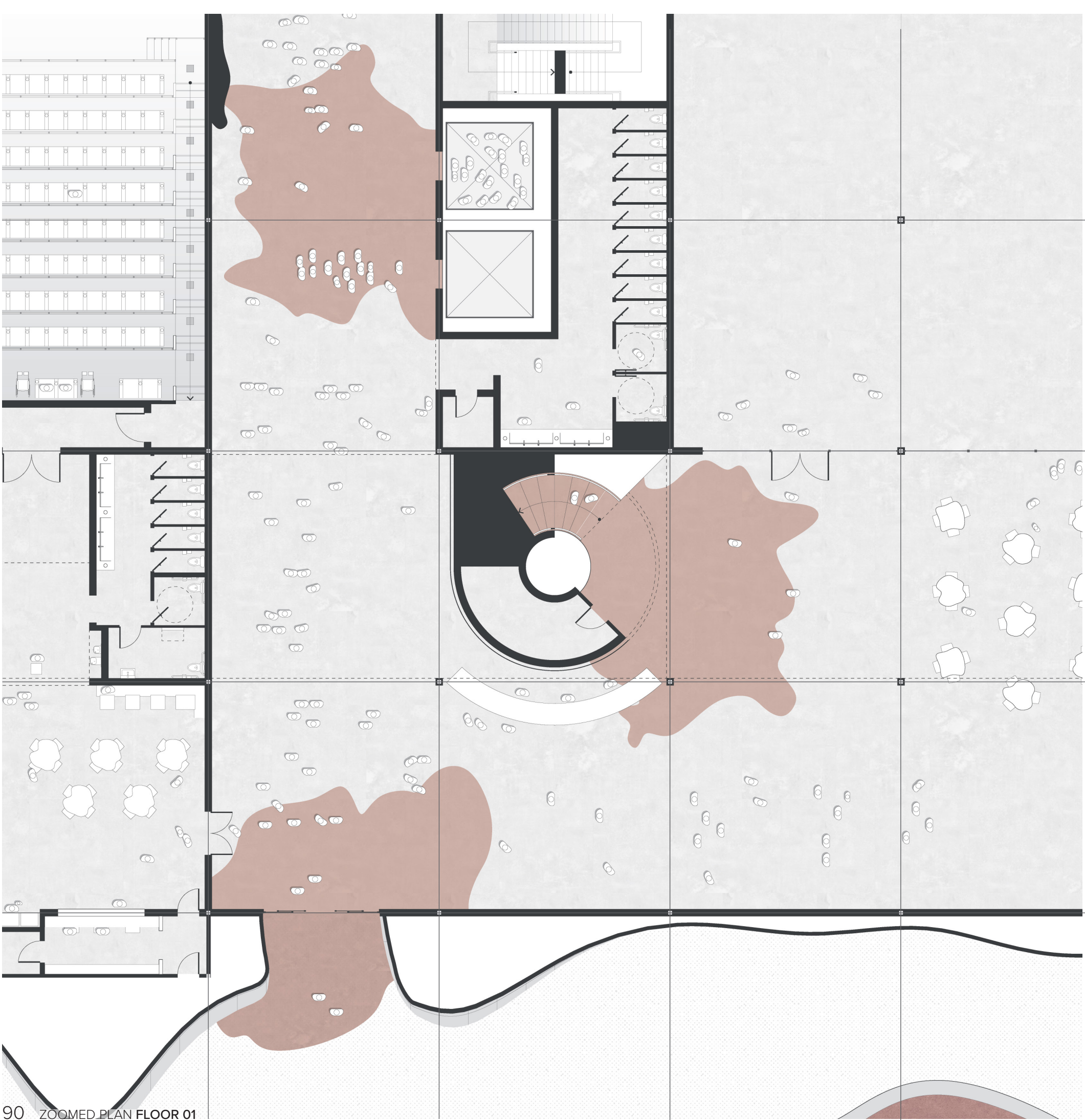

90 ZOOMED PLAN FLOOR 01



ZOOMED PLAN FLOOR 03



**ZAHNER IMAGE WALL ON DROP & LOCK METAL PANEL SYSTEM**

“ImageWall perforated metal panel systems enhance lobbies, decorate parking garages, refresh aging interiors, partition outdoor spaces, and more. Use ImageWall to bring patterns, logos, words, and images of all kinds to life in your designs through durable, affordable perforated metal.” (Zahner)

“Drop & Lock systems developed by Zahner use Inverted Seam technology to enable fast and sealant-free installation of metal panels and other hardware for architectural systems.” (Zahner)

The Zahner Drop & Lock system was previously selected for the exterior wall panels. This wall system also happens to be used in the ImageWall metal panel systems. The panel system is used to enhance the surrounding of the spiral staircase and continue themes from the exterior facades.

One common design element that will be present throughout the building is horror movie easter eggs. Including small nods to horror movies will not only contribute to design decisions, but will give horror fans something to look for as they make their way through the building.

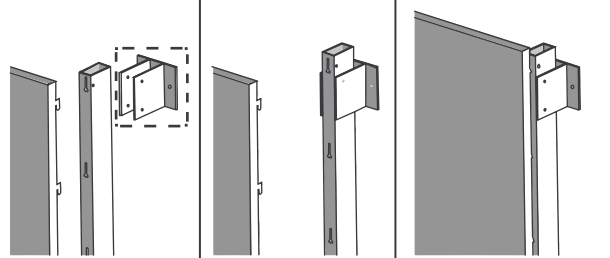
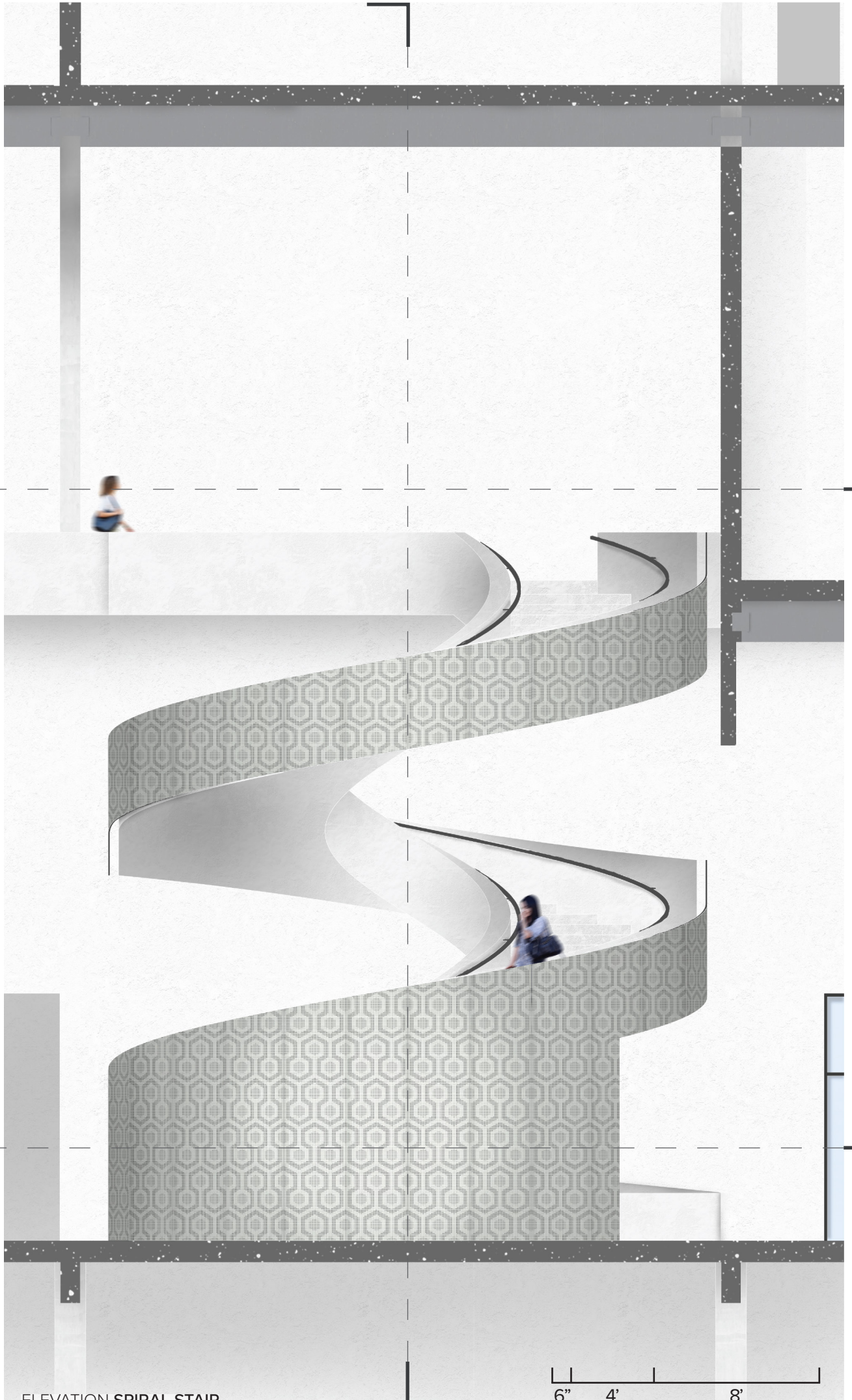
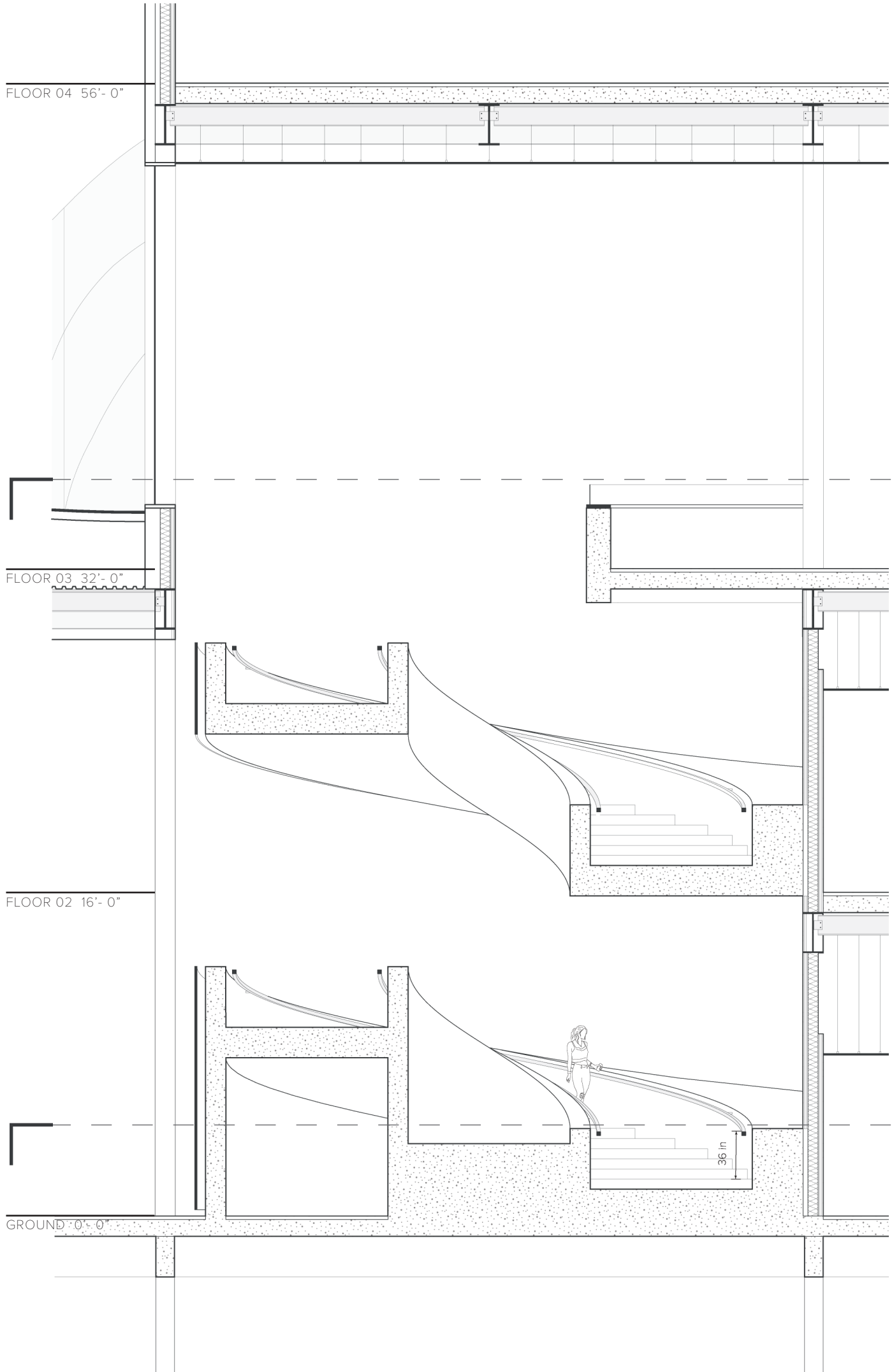

ZAHNER DROP & LOCK SYSTEM N.T.S

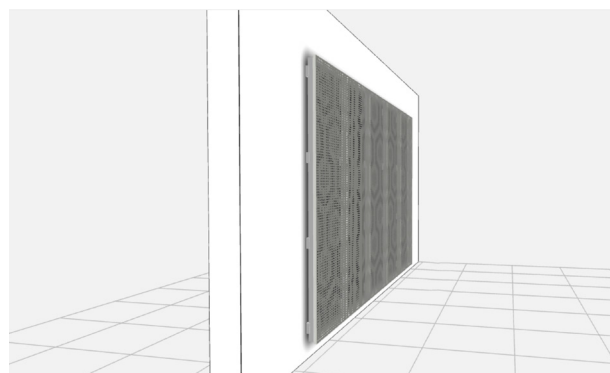
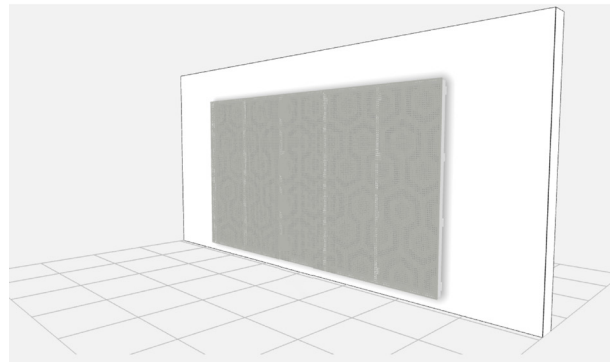
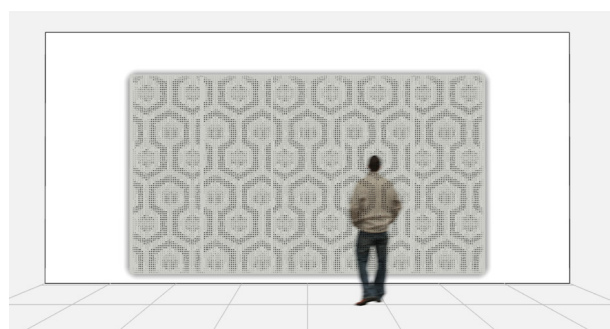

ZAHNER IMAGEWALL

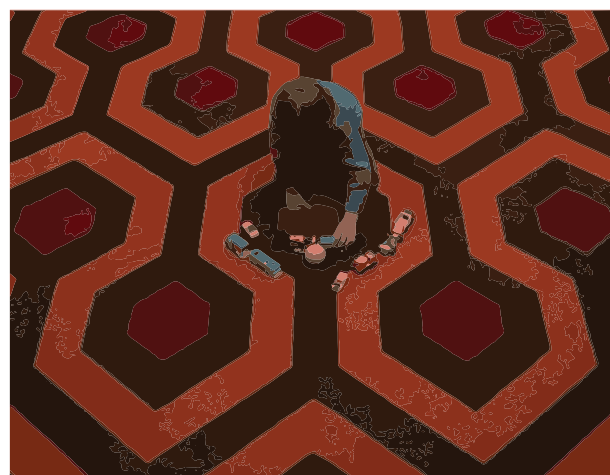

THE SHINING (1980) CARPET REFERENCE



The fourth floor hosts the captivating Horrified exhibit, where guests are greeted with an orientation space upon exiting the elevators. Here, they are mentally prepared for the immersive experience that awaits them. The orientation space also features a small historical gallery and viewing areas for the large-scale exhibit on the third floor, offering guests a preview of what's to come.

Adjacent to the elevators lies a dynamic VR/AI/Technological space, drawing inspiration from recent immersive art experiences like those found at Artechouse and Meow Wolf. This area showcases interactive exhibits utilizing VR/AI technology, echoing the engaging nature of past installations such as 'The Science Behind Pixar,' which was previously featured at the neighboring Perot Museum.

Positioned near the service core is a kitchen serving the special event space, available for reservation for various occasions, including movie premieres. The balcony of this space provides a unique perspective, offering both a glimpse of a small piece of skin attempting to infiltrate the building and a panoramic view of Downtown Dallas.

- 1 HISTORICAL GALLERY
- 2 TECHNOLOGY BASED EXHIBIT SPACE
- 3 EXHIBIT ORIENTATION SPACE
- 4 LARGE SCALE UPPER LEVEL
- 5 HORRIFIED EXHIBIT
- 6 QUIET ROOM
- 7 MEDICAL
- 8 EXIT
- 9 SPECIAL EVENT KITCHEN
- 10 SPECIAL EVENT SPACE
- 11 RESTROOMS
- 12 STORAGE

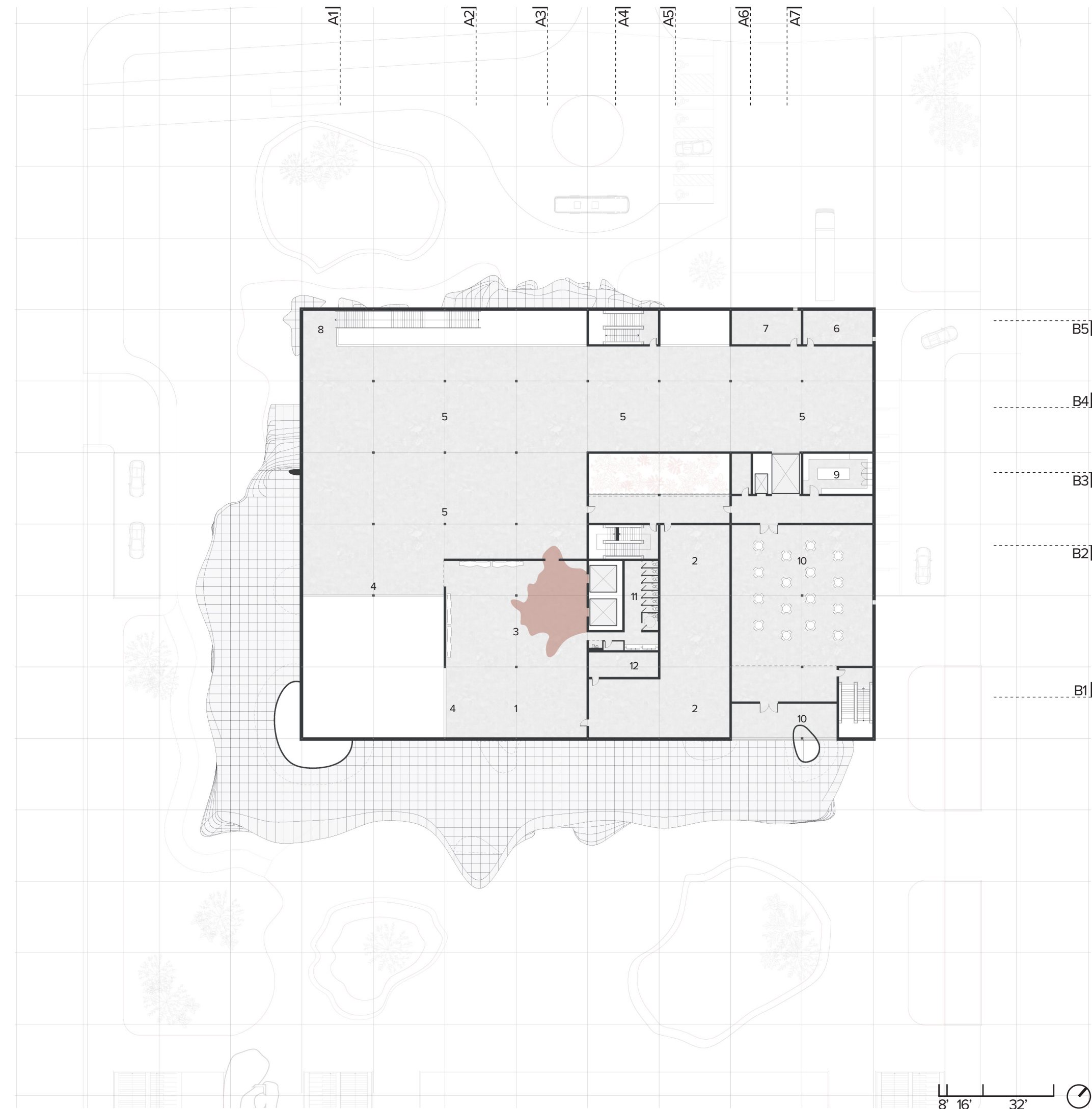

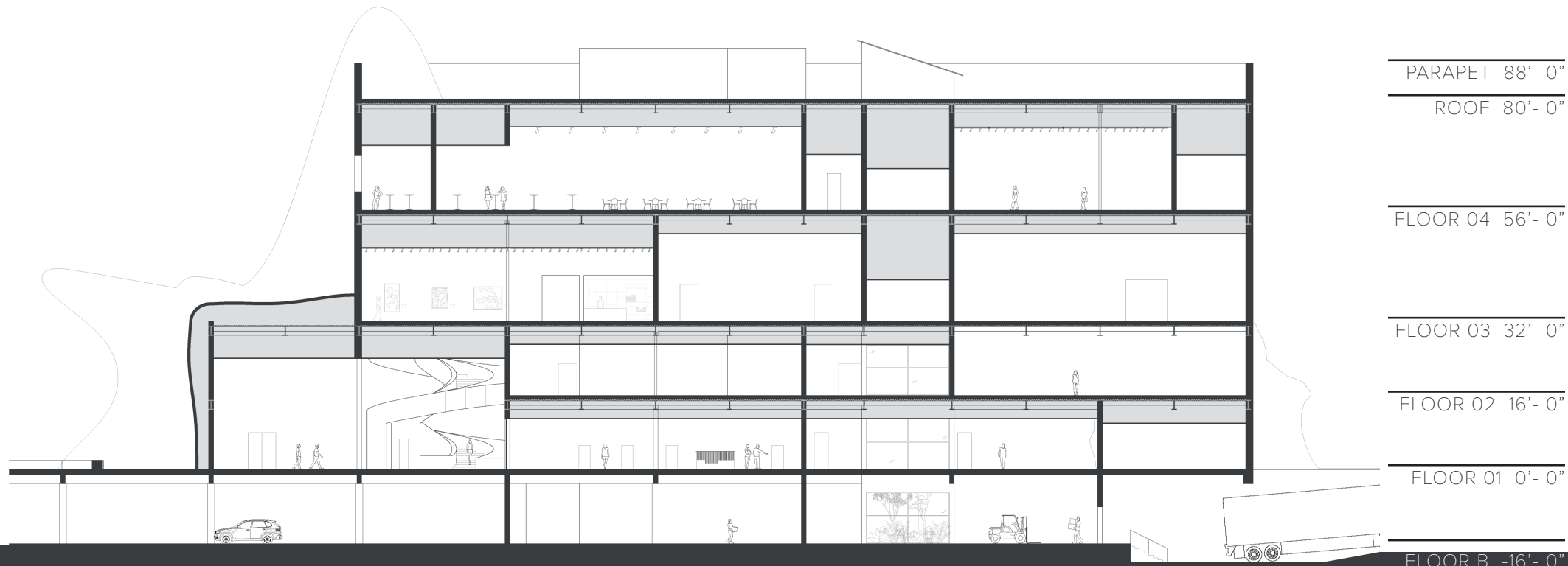

PARAPET 88'-0"

ROOF 80'-0"

FLOOR 04 56'-0"

FLOOR 03 32'-0"

FLOOR 02 16'-0"

FLOOR 01 0'-0"

FLOOR B -16'-0"

BUILDING SECTION A6



PARAPET 88'-0"

ROOF 80'-0"

FLOOR 04 56'-0"

FLOOR 03 32'-0"

FLOOR 02 16'-0"

FLOOR 01 0'-0"

FLOOR B -16'-0"



BUILDING SECTION B3

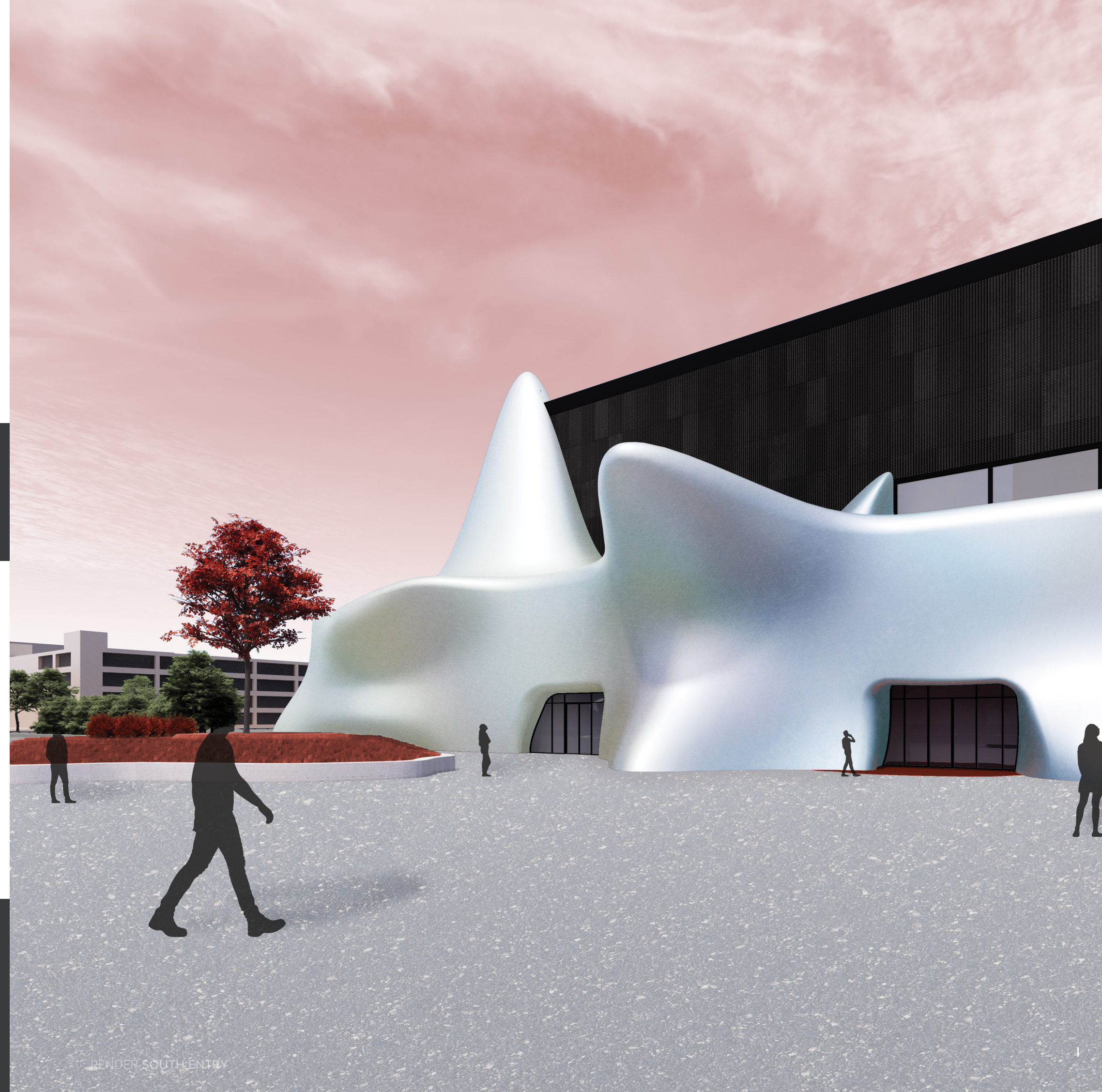

RENDER SOUTHENTRY



000

HOMUNCULISM

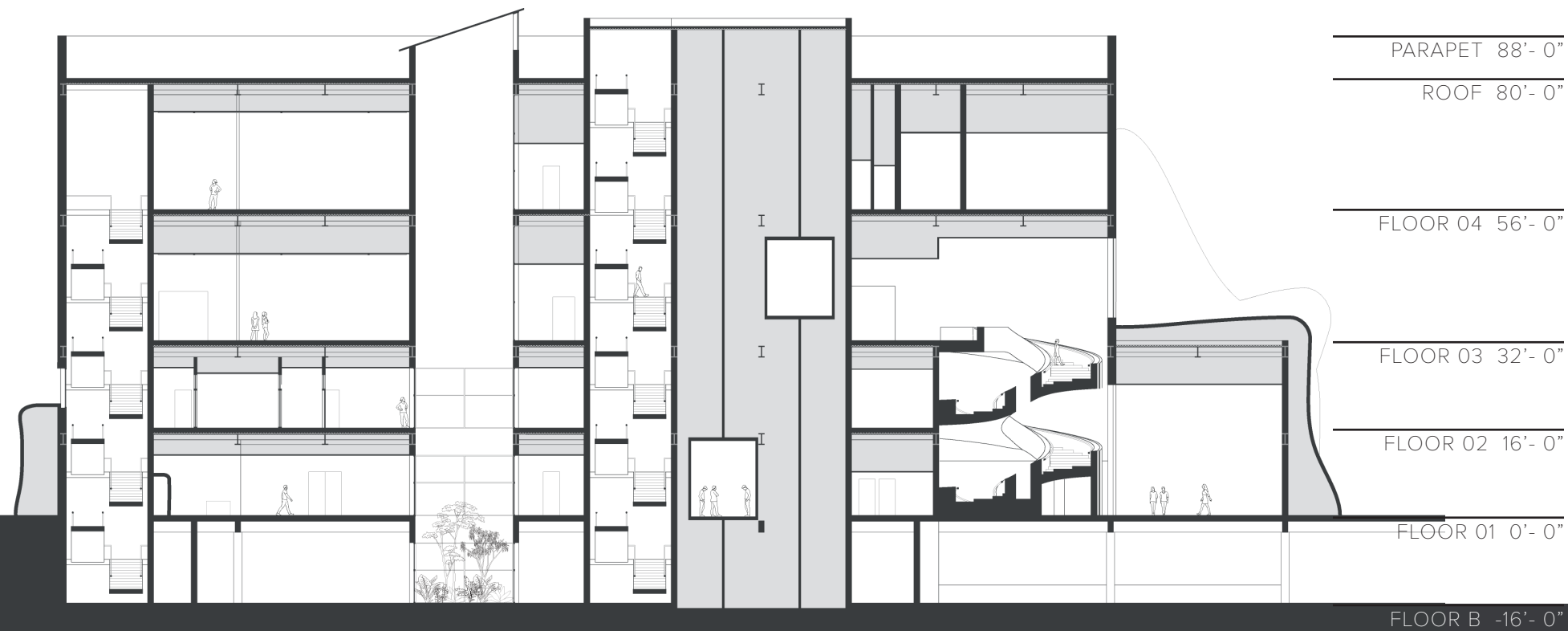

FLOOR B -16'- 0"

PARAPET 88'- 0"

ROOF 80'- 0"

FLOOR 04 56'- 0"

FLOOR 03 32'- 0"

FLOOR 02 16'- 0"

FLOOR 01 0'- 0"



Effective circulation is vital in all multi-story buildings, particularly in crafting immersive experiences. Elevators, serving as key transit points, can be transformed into dynamic spaces with the integration of advanced technology. Floors and walls within these elevators can function as screens, capable of morphing into various visual illusions—a pool of blood, a menacing creature, or the sensation of the floor dropping away. Integrating AI and motion sensor technology, these screens can interact with guests, generating bloody footprints as they move. A precedent for such innovation was set in the PIXELBOOM exhibit at Artechouse in D.C., where similar techniques were employed with digital art. Alongside these cutting-edge visual elements, traditional electrical systems will complement the experience with eerie sounds, flickering lights, and other unsettling effects. These features will extend beyond the elevators, permeating the entire building, including the parking garage, exhibit spaces, corridors, and even restrooms. Furthermore, the elevators themselves will possess a chilling intelligence, emitting sounds of attempted escape when summoned to an empty floor, only to reveal their vacancy upon opening. This integration of technology not only enriches the museum experience but also signifies a broader evolution in the definition and function of museums. It underscores the continual transformation of museum spaces into dynamic, interactive environments that provoke and engage visitors in new and innovative ways.

Building upon the concept of circulation, the lobby entrances, elevator exits, and staircases feature striking red polished concrete, extending and pooling at their terminations. These surfaces bear patterns derived from real blood as well as homemade experimentations using strawberry puree. This is a nod to the incontinent object, a *Horror in Architecture* trope, where the building is unable to control the release of what is within as a way of herniation and pollution (Comaroff & Ker-Shing, 2013, 128). Exiting these blood pools are footprints that mysteriously seem to disappear.

From a technical standpoint, the project entails meticulous attention to structural and system details. The basement level and all circulation cores consist of thick cast-in-place concrete walls. Additionally, the floors consist of concrete slab on composite decking, following a structured layout based on a 32 x 32 foot grid, simplifying the steel framing throughout the building. Girders, typically 24" deep, span 32 feet, except for the movie theater and large exhibit space, which require 48" deep girders to support spans of 64 feet. Above-grade columns are HSS6, while non-embedded basement columns are 10" concrete columns. Metal beams, 12" deep with a 16-foot span, are strategically placed to minimize beam span. Floor-to-floor heights vary, with the basement through floor two at a minimum of 16 feet and floors three and four reaching 24 feet. A total of three feet is allocated for flooring and structural systems, with an additional minimum of 3 feet provided to accommodate duct and electrical systems before drop ceilings are installed. Given the stringent requirements of museums, maintaining optimal temperature and humidity levels—approximately 70 degrees Fahrenheit and 54% relative humidity—is imperative to preserve collection pieces and prevent any adverse effects.



80'-0" A.F.F.  
FLOOR 04

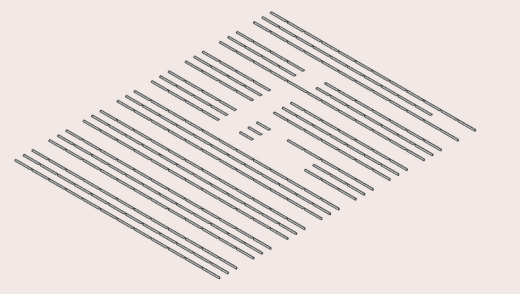
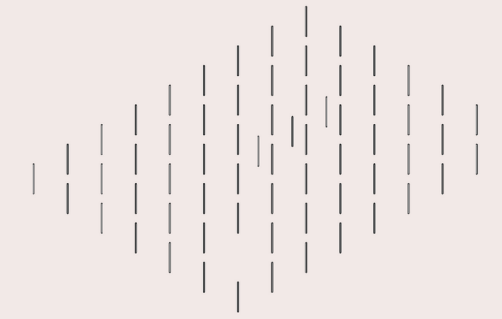
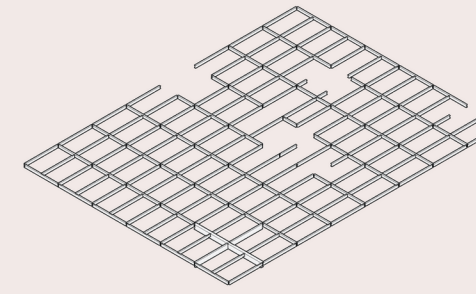
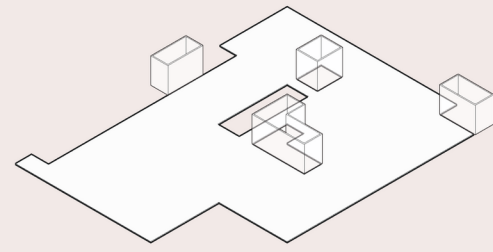
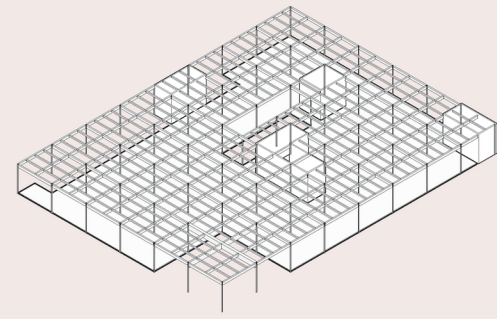

56'-0" A.F.F.  
FLOOR 03

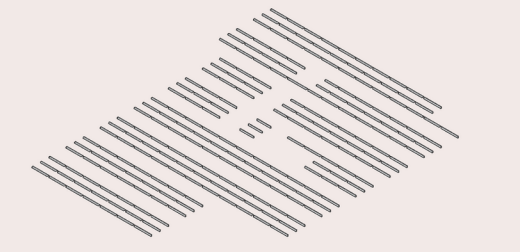
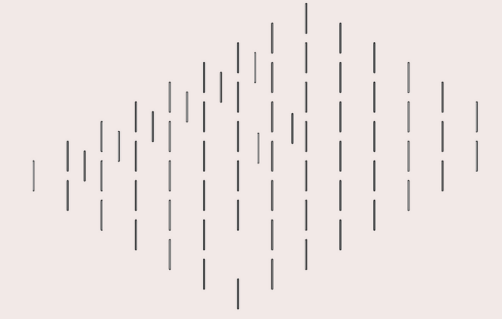
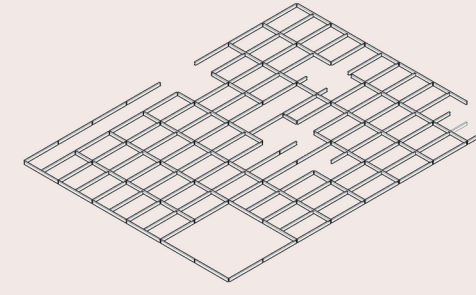
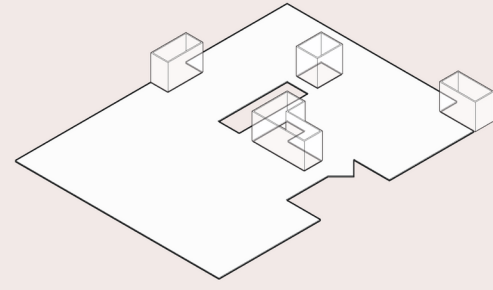
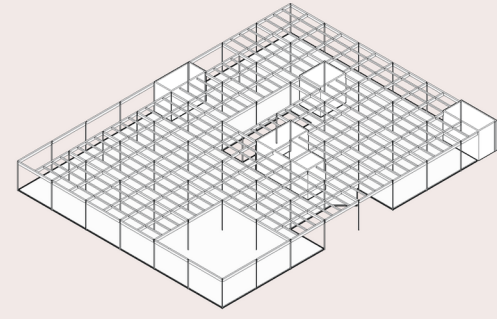

32'-0" A.F.F.  
FLOOR 02

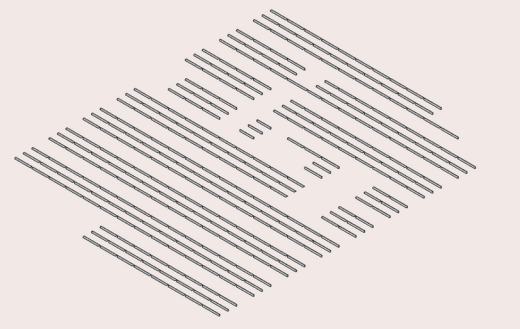
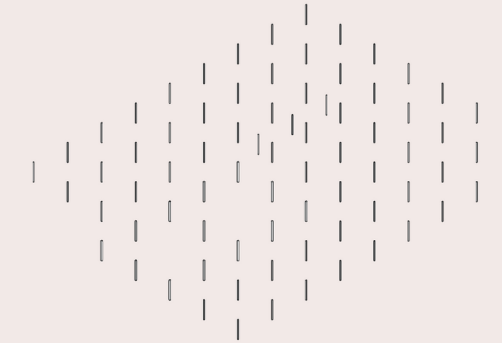
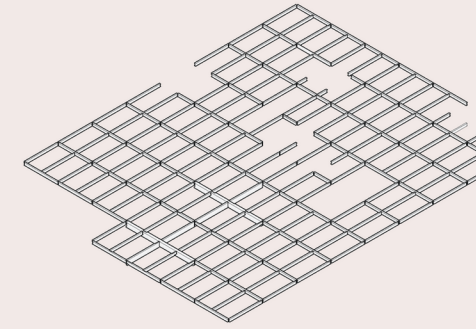
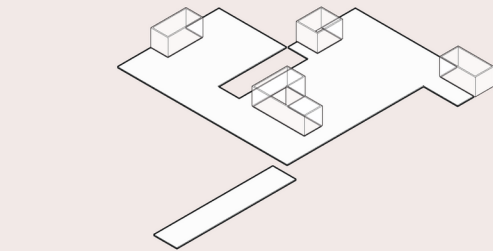
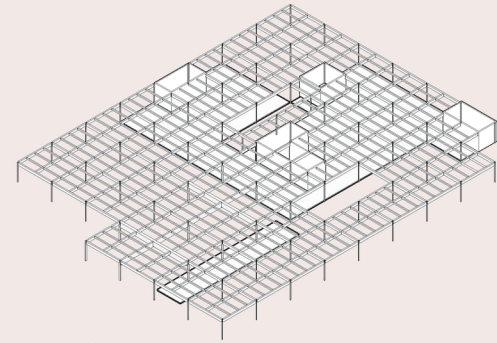

16'-0" A.F.F.  
FLOOR 01

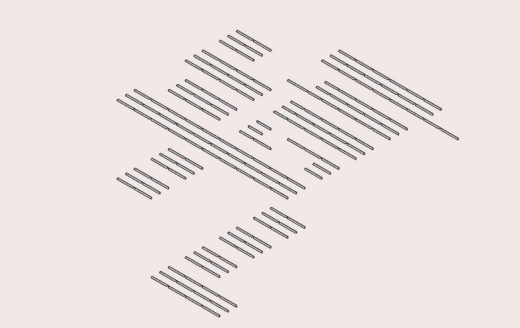
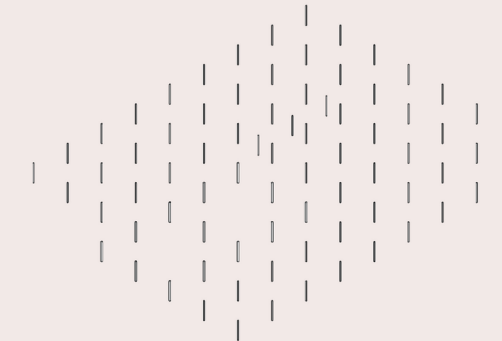
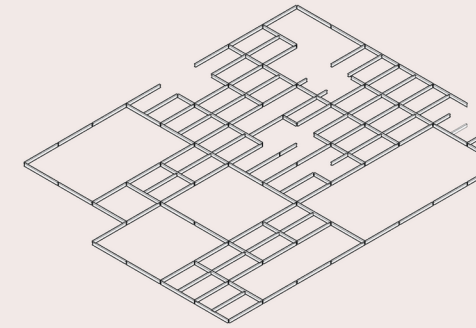
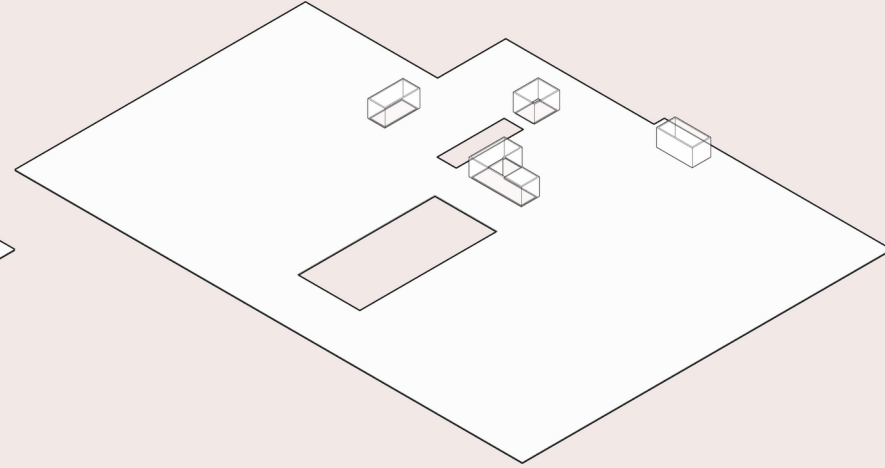
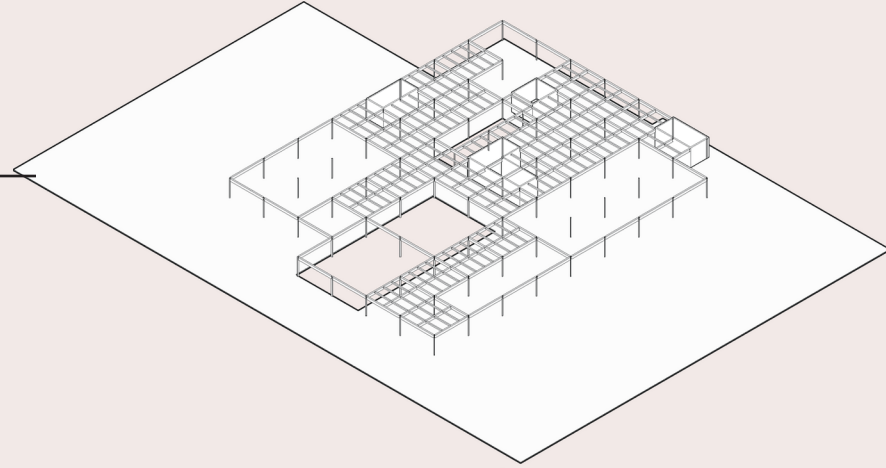

0'-0" A.F.F.  
FLOOR B

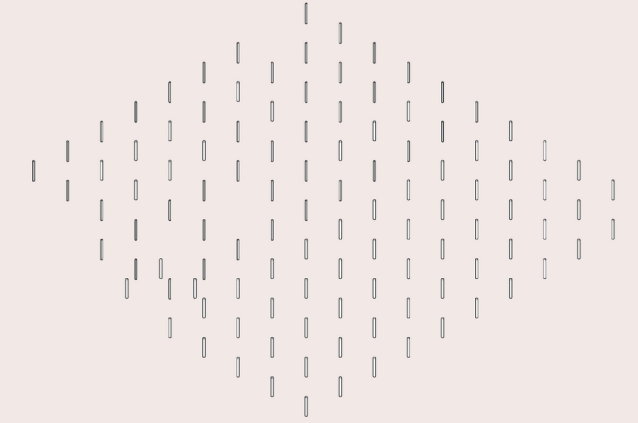
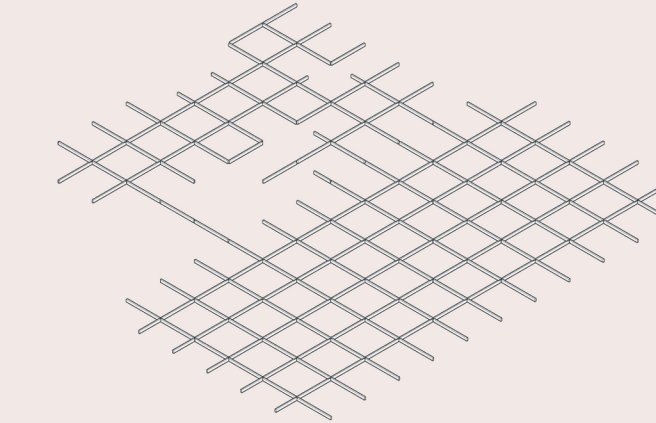
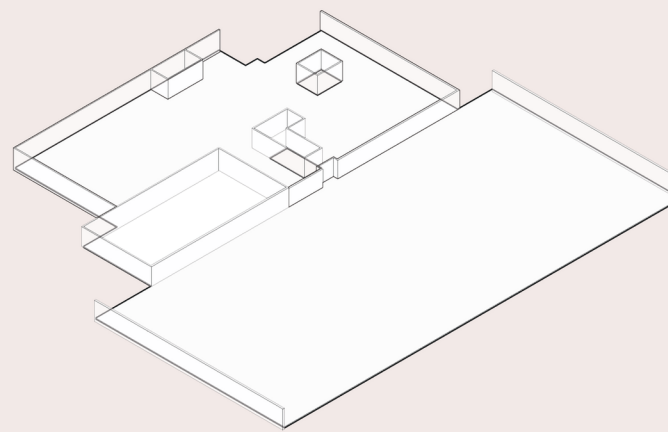
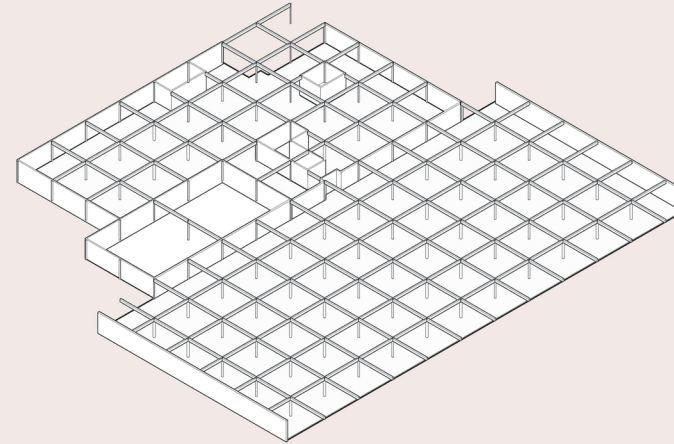

**Floors + Retaining Walls**

Concrete Slab

12" Cast-In-Place Walls

**Girders**

24" Deep w/ 32' span (typ.)

48" Deep w/ 64' span

**Columns**

HSS6 (typ.) Fl. 01-04

10x10 concrete Fl. B

**Beams**

12" Deep w/ 16' span (typ.)



I personally find the idea behind the Horrified exhibit the most fascinating aspect of the project, and something I wish could have been further explored. It was what I had initially set out to achieve when I was brainstorming, even before the Architectural Programming class. My original architectural question, prior to the start of this project was “how can architecture be used to evoke unsettling emotions?” As an architecture student rather than one specializing in exhibit design, visually achieving this aspect within the project’s context is beyond my current capability. However, as the primary driving force and namesake behind the project, it has remained a central theme throughout its development and must be effectively expressed. The premise behind Horrified is a one-way path through an exhibit that gets increasingly scarier. This is achieved through both exhibit content and the ambience of the visitors surroundings., with the start of the exhibit being simple, originally the location for the history of horror, and the end being haunted house level terrifying. Contributing to the cause of visitor’s anxiety and fear is the use of the previously mentioned electrical systems producing light, color, sound, and temperature changes. Furthermore, employees will perform haunted house style acting to further contribute to the anxiety and fear of the guests.

Prospect and refuge are two aspects of physical space that were intentionally avoided within this project. **“Refuge means having a secure, protected place to hide where one can be sheltered from danger, while prospect refers to one’s clear, unobstructed view of the landscape,”** (McAndrew, 2020) and without them, one feels trapped and uneasy. The building is relatively open with few places to hide, as well as a lack of view to exterior spaces. Once entering the building, the true outside is not seen again until descending the spiral exit staircase. In the case of the ‘Horrified’ exhibit, there are just two places for visitors to receive a feeling of both refuge and prospect. Located on the North wall, towards the end of the exhibit, is a medical room and a quiet room. Everyone thinks they are ready for the worst horror until they experience it. A waiver will be signed prior to the purchasing of tickets, but it is necessary for the safety of the guests and liability of the museum that there be medical care and safe spaces available within the facility.

# CONCLUSIONS



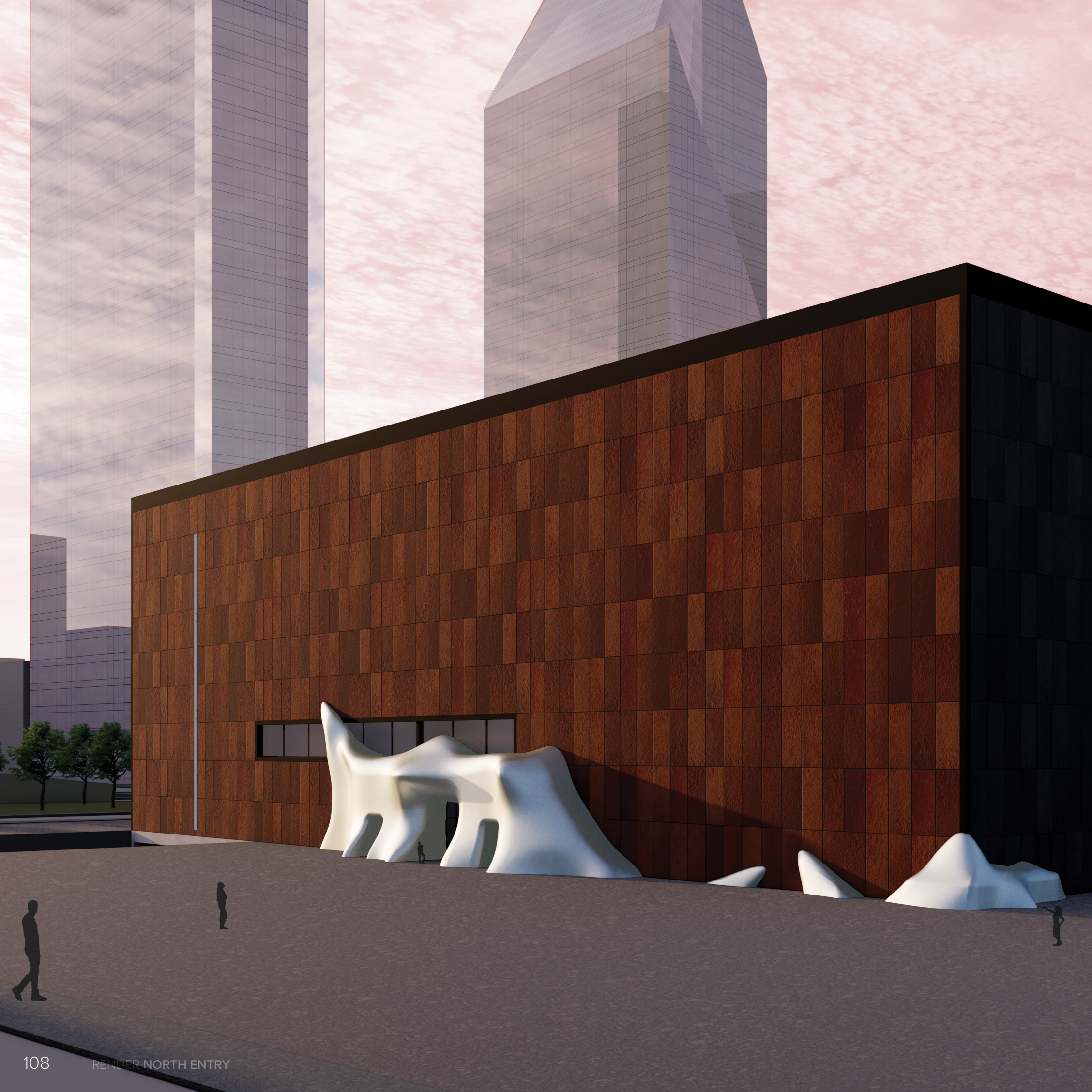

This final study project has explored what it means to be a 'museum' in the 21st century, discovering that, like horror movies, it is an evolutionary concept that revolves around societal change and the inventions of new technology. The research has delved into the evolving museum experience, the potential trajectory of museums in the future, the essence of architectural horror, and the methods through which architectural elements can evoke unease among museum visitors. The Horror Movie Museum is all about immersion and experience, while consistently touching back to the learning and display aspects found in traditional museum experiences. The swift advancement of technology is enabling the display of new forms of art and materials. This rapid evolution prompts the question of whether traditional "museums" remain aptly named or if a new classification is warranted to encompass these advances.



## WORKS CITED

- Achleitner, F., & von Moos, S. (1999). *Museums for a New Millennium: Concepts, Projects, Buildings* (V. Magnago Lampugnani, A. Sachs, & S. v. Moos, Eds.). Prestel.
- Burke, E. (1968). *A Philosophical Enquiry Into the Origin of Our Ideas of the Sublime and Beautiful* (J. Boulton, Ed.). South Bend: University of Notre Dame Press.
- Comaroff, J., & Ker-Shing, O. (2013). *Horror in Architecture*. ORO editions
- Comaroff, J., & Ker-Shing, O. (2024). *Horror in Architecture: The Reanimated Edition*. University of Minnesota Press.
- Crimm, W. L., Morris, M., & Wharton, L. C. (2009). *Planning Successful Museum Building Projects*. AltaMira Press.
- Des Pres, T. (1983, May). Terror and the Sublime. *Human Rights Quarterly*, 5(2), 135-146. 10.2307/762250
- Eggener, K. (2013, October). When Buildings Kill. *Places Journal*. <https://doi.org/10.22269/131029>
- Flight, T., & Lazarraga, W. (2020, January 28). *The Visual Architecture of Parasite*. YouTube. from <https://youtu.be/AvO8-925Edc>
- Gensler. (n.d.). *AT&T Discovery District | Gensler*. Gensler DXD. Retrieved April 11, 2024, from <https://dxd.gensler.com/case-studies/att-discovery-district>
- Hourston, L. (2004). *Museum Builders II*. Wiley-Academy.
- McAndrew, F. T. (2020). The Psychology, Geography, and Architecture of Horror: How Places Creep Us Out. *Evolutionary Studies In Imaginative Culture*, 4(2), 47-62. <https://doi.org/10.26613/esic.4.2.189>
- Merriam-Webster. (n.d.). *Museum Definition & Meaning*. Merriam-Webster. Retrieved August 11, 2023, from <https://www.merriam-webster.com/dictionary/museum>
- MoPOP. (n.d.). *Scared to Death: The Thrill of Horror Film*. MoPOP. Retrieved April 10, 2024, from <https://www.mopop.org/exhibitions-plus-events/exhibitions/scared-to-death-the-thrill-of-horror-film/>
- NYFA. (2022, July 21). *The First Horror Movie & The History of the Horror Genre*. New York Film Academy. Retrieved February 9, 2024, from <https://www.nyfa.edu/student-resources/how-horror-movies-have-changed-since-their-beginning>
- Pena, W. M., & Parshall, S. A. (2012). *Problem Seeking: An Architectural Programming Primer* (5th ed.). Wiley.
- Plus 1 Architecture. (2020, October 31). *Can Architecture Be Scary? - Architect Analyzes Horror Films*. Youtube. from <https://youtu.be/ij5TeGdy9Dg>
- Populous. (n.d.). *Sphere*. Populous. Retrieved April 12, 2024, from <https://populous.com/project/sphere>
- Poth, A. (2019, October 29). *Why Do We Enjoy Fear? - Texas A&M Today*. Texas A&M Today. from <https://today.tamu.edu/2019/10/29/why-do-we-enjoy-fear>
- Smith, C. S. (2021). *The Art Museum In Modern Times*. Thames & Hudson.
- Torre, I. (2012, October 31). *L'horreur! Evolution of the scary movie*. CNN. Retrieved April 11, 2024, from <https://www.cnn.com/2012/10/31/world/halloween-movie-timeline>
- Walshaw, E. (n.d.). An Architect's Guide To: *Museum Planning*. *Architizer*. from <https://architizer.com/blog/practice/details/architects-guide-museum-planning/>
- Woods, H. (2022, October 19). Architect Breaks Down 5 Haunted Houses From Scary Films | Architectural Digest. Youtube, uploaded by Architectural Digest, from <https://youtu.be/GGrKSsMO4LY>
- Vox. (2018, November 13). *Why the Victorian mansion is a horror icon*. YouTube, uploaded by Vox, from <https://youtu.be/2xvNhN1PsRw>
- Zahner. (n.d.). *Drop & Lock™*. Zahner. Retrieved January 6, 2024, from <https://www.azahner.com/systems/drop-lock>
- Zahner. (n.d.). *ImageWall Product Information*. Zahner. Retrieved January 6, 2024, from <https://www.azahner.com/systems/imagewall>
- Zahner. (n.d.). *ZEPPS™*. Zahner. Retrieved January 6, 2024, from <http://www.azahner.com/zepps>

## IMAGE SOURCES

- 08: wallpapercave.com
- 10: Iwan Baan, 2012
- 12: CNN.com
- 14: Behance.com; MoPOP.com
- 18: wallpapers.com
- 26: dc.aiga.org; archdaily.com; cntraveler.com; fortwortharchitecture.com
- 34: deviantart.com
- 38: urbanautica.com; nationalgalleries.org; metropolismag.com
- 42: 4kwallpapers.com
- 44: ARTnews.com
- 47: medium.com; archello.com; champ-magazine.com
- 52: textures4photoshop.com; istock.com
- 53: architecturaldigest.com; magazine.texasarchitects.org
- 60: writeups.org
- 64: landezine.com
- 70: people.com
- 76: filmartgallery.com; ew.com; amazon.com; imdb.com
- 82: architonic.com
- 85: wikipedia.com
- 93: filmandfurniture.com
- 98: amazon.com
- 106: facebook.com